

HOME ROW QUICK REFERENCE CHART - FrogPad™ BLACK

Right Hand Layout

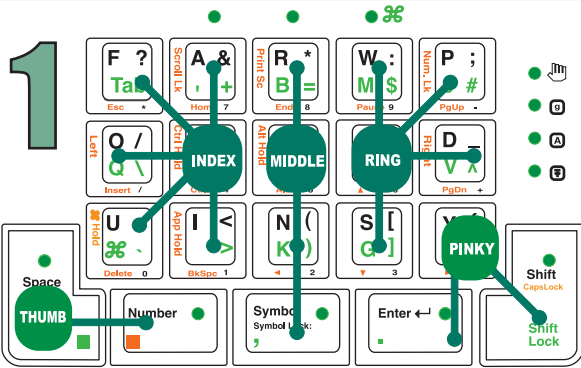

Place fingers slightly bent on the 'HOME ROW' key position as shown. the pointers indicate which key each finger is responsible for hitting.

Symbols & Command Key-⌘

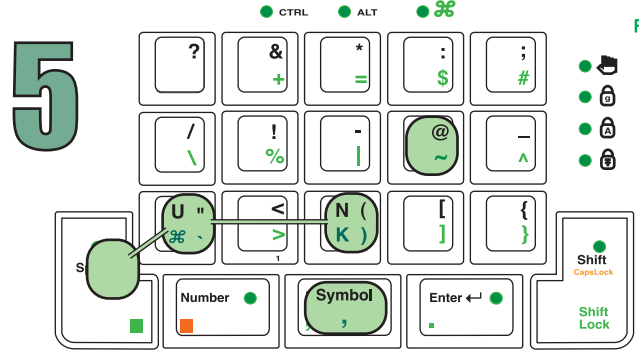

FROGGY SAYS:
For GREEN symbols - hit Symbol then follow step 3.

Pressing and releasing the Symbol key will initiate Symbol Mode. Enter black colored symbols by pressing and releasing that key alone. The ⌘ key is the Command key (also is PC Windows® key). Press the Space key and then simultaneously press the ⌘ key (the U key) to activate .⌘ will only be applied to next key; i.e. 'N for NEW'.

Primary Lowercase Letters (Black)

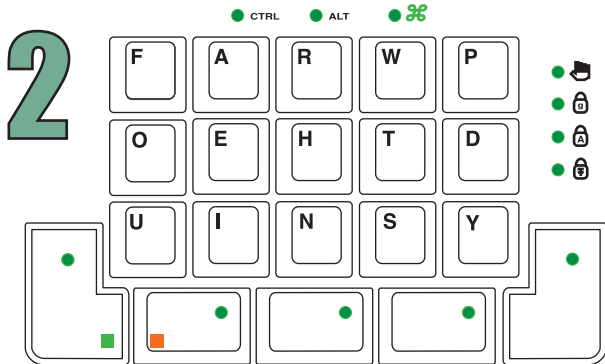

To enter a Primary Lowercase Letter, press and release that key. The letter is entered when the key is released.

Numbers

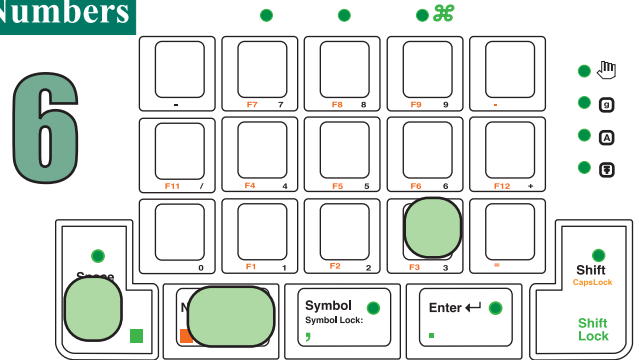

Pressing and releasing the Number key will initiate Number Mode. To enter F1 thru F12 keys in the number mode, simply press the green Thumb key and corresponding number (1 thru 9 with 0 for F10) F11 & F12 are on sides of row 2. <Number> alone brings up the Number Mode with keypad coding (shown as "KP Num"); <Space> + <Number> brings up Number Mode with keyboard coding (shown as "KB Num"); consecutive pressing of <Number> alone does this: [KB Pad] -> [KP Num] -> [Letter Mode]

Secondary Lower case Letters (Green)



FROGGY SAYS:
If the THUMB KEY is not pressed at the same time as the letter, a black letter will be entered.

In order to enter a green letter, you must press that key and the GREEN THUMB KEY simultaneously. It doesn't matter which key is pressed first- the letter is entered when both keys are depressed simultaneously and released.

Orange Functions

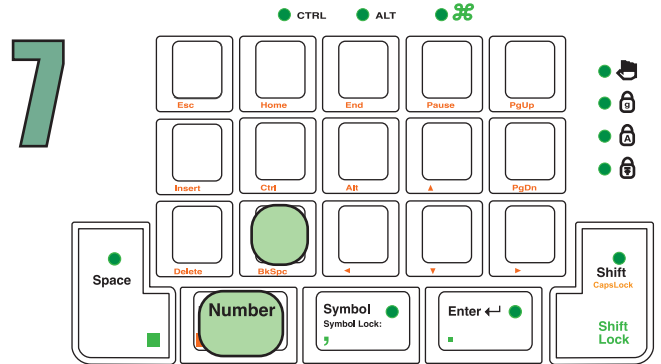

Simultaneously pressing the Orange (Number) thumb-key and desired function key will enter that function. The Control or Alt keys will remain active after they are pressed and released. Press and release to disable.

Capital Letters



FROGGY SAYS:
For GREEN Capital Letters - hit Shift then follow step 3.

Press Shift ONCE and the Shift Light blinks to indicate that CapsLock will be applied to the next letter. Once the letter is entered, CapsLock will then be cancelled. Pressing Space by itself generates a space. Press Space and any letter key simultaneously to obtain the secondary bottom-left GREEN letter for that key. The <F> and <A> keys have tab and apostrophe, respectively. For the <U> key see section 5.

Special Mode

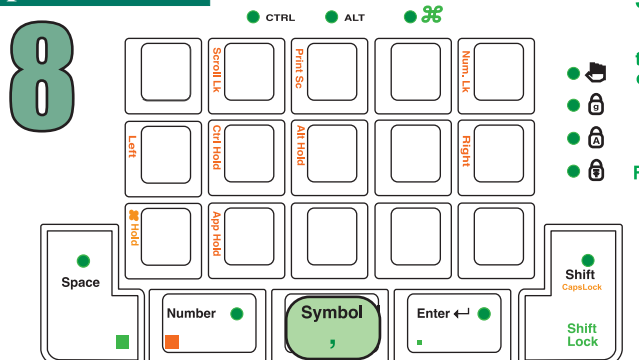

FROGGY SAYS:
To get Break, turn Ctrl on, then press Pause (<W> in the Function Mode).

For Special Mode, Initiate Symbol Mode (Step 5) then hold Number key while simultaneously pressing a Special Mode key.