



SmartPad™



User's Guide

**Seiko Instruments USA Inc.
2990 Lomita Boulevard**

Torrance, California 90505
www.seikosmart.com

Trademarks and Copyright

SmartPad, the SmartPad logo, InkLink, the InkLink logo, and InkNote Manager, are trademarks of Seiko Instruments USA Inc.

Copyright 2002, Seiko Instruments USA Inc.

All rights reserved. Seiko Instruments products contain certain trade secrets and confidential and proprietary information. Use, reproduction, disclosure and distribution by any means are prohibited, except pursuant to a written license from Seiko Instruments USA Inc. Use of Copyright Notice is precautionary and does not imply publication or disclosure. Other products and brand names may be trademarks or registered trademarks of their respective owners.

Disclaimer and Limitation of Liability

Seiko Instruments USA Inc. assumes no responsibility for any damage or loss resulting from the use of this product.

Seiko Instruments USA Inc. assumes no responsibility for any loss or claims by third parties that may arise through the use of this software.

Seiko Instruments USA Inc. assumes no responsibility for any damage or loss caused by deletion of data resulting from malfunction, dead batteries, or repair. Be sure to make backup copies of all important data on other media to protect against data loss.

Important: Please read the Seiko Instruments USA Inc. End User Software License Agreement before using the accompanying software program(s). Using any of the software indicates that you accept the terms of the End User Software License Agreement.

Restricted Rights Legend

Use, duplication, or disclosure by the Government is subject as set forth in subparagraph (c) (1) (ii) of the Rights in Technical Data and Computer Software clause at DFARS 52.227-7013.

Contents

Introduction 11

Introducing the InkLink Handwriting System 12

How InkLink Works 12

InkLink Features 12

Introducing SmartPad 14

How SmartPad Works 14

SmartPad Features 14

Introducing InkNote Manager 16

InkNote Manager Software on your handheld 17

*InkNote Manager Software on your Desktop
Computer 17*

*InkNote Manager Works the Same on Both
Computers 17*

InkNote Manager Features 17

Setting Up 19

System Requirements 19

Desktop Computer 20

Pocket PC 20

Palm OS PDA 21

Software Setup 21

Confirming that HotSync is Working 21

Confirming that ActiveSync is Working 22

Installing InkNote Manager Software 22

Setup Tips 23

InkLink Setup 24

Product Box Contents 24

Installing the IrDA Transceiver Battery 25

Installing InkLink Pen Batteries 26

Attaching the InkLink Data Clip 26

Connecting to a Handheld 28

Connecting to a desktop 28

InkLink Basics 29

Using the InkLink Pen 29

Placing InkLink in the Carrying Case 31

SmartPad Setup 32

Product Box Contents 32

<i>Installing the SmartPad Portfolio Batteries</i>	33
<i>Repositioning the Infrared Transceiver</i>	34
<i>Attaching Your handheld</i>	35
Starting InkNote Manager	36
<i>Starting InkNote Manager on a Pocket PC</i>	36
<i>Starting InkNote Manager on a Palm OS handheld</i>	37
<i>Starting InkNote Manager on a Desktop computer with InkLink</i>	37
<i>Selecting a handheld as a Partner</i>	38

Getting Started **41**

Explorer	41
Note Editor	43
Help	45
<i>Getting Help</i>	45

Creating Ink Notes **47**

Ink Notes	48
<i>Selecting a Paper Size</i>	48
<i>Defining a Paper Size</i>	49
<i>Creating an Ink Note</i>	50
<i>Adding a Page</i>	50
<i>Saving an Ink Note</i>	51
<i>Deleting an Ink Note</i>	51
<i>Exporting an Ink Note</i>	52
<i>Closing Note Editor</i>	54

Organizing and Finding Ink Notes **55**

Why Organize?	55
<i>Finding an Ink Note in Explorer</i>	57
<i>Changing Explorer Views</i>	58
<i>Assigning Categories and Keywords</i>	59
<i>Setting Up Categories</i>	62
<i>Renaming an Ink Note</i>	62

Creating an Action Item 63

Editing Ink Notes 65

Working with Ink Notes 66

Opening an Ink Note 66

Zooming and Panning 67

Navigating Between Pages 68

Using the Pen Function Keys 69

Using Pen Gestures on SmartPad 70

Displaying or Hiding Ruled Lines 71

Adding to an Ink Note 72

Drawing Straight Lines 73

Straightening Existing Lines 74

Adding a Highlight 74

Setting Ink and Highlight Colors 75

Selecting Parts of an Ink Note 76

Using Cut, Copy, and Paste 77

Moving Part of an Ink Note 78

Grouping and Ungrouping Parts of an Ink Note 78

Undoing an Edit 79

Using Handwriting Recognition 79

Communicating Notes 81

Sending Ink Notes 81

E-mailing an Ink Note 82

Beaming an Ink Note 83

Printing an Ink Note 83

Archiving and Backing Up 85

Why Archive? 85

Setting Archive Options 86

Viewing Archived Ink Notes 87

Restoring Archived Ink Notes 87

Archiving Intermediate Versions 88

Advanced Tasks **89**

Other Configuration Options 89

Setting the Default File Name **90**

Using the SmartPad Tablet as a Keyboard **90**

Power-Saving Features **91**

Using InkNote Manager with Multiple handheld Devices **95**

Choosing a Sync Partner **96**

Specifying a Storage Location for Your Ink Notes **96**

InkLink Maintenance Procedures 97

Replacing the InkLink Pen Ink Cartridge **97**

Replacing the InkLink Pen Batteries **98**

Replacing the InkLink IrDA Transceiver Battery **99**

SmartPad Maintenance Procedures 99

Replacing the SmartPad Pen Ink Cartridge **100**

Replacing the SmartPad Pen Battery **101**

Replacing SmartPad Portfolio Batteries **102**

Repositioning the SmartPad 2 Infrared Transceiver **103**

Attaching Your handheld To SmartPad **104**

InkNote Manager Maintenance 106

Uninstalling InkNote Manager from a Desktop Computer **106**

Uninstalling InkNote Manager from a Pocket PC **106**

Uninstalling InkNote Manager from a Palm device **107**

Upgrading InkNote Manager **107**

Troubleshooting **109**

Testing the handheld and InkLink or SmartPad **110**

InkLink Ink Strokes Do Not Appear on the screen **110**

SmartPad Ink Strokes Do Not Appear on the screen **111**

InkLink ink notes do not match paper notes **112**

InkLink does not work reliably **112**

Screen Blanks While Writing **113**

SmartPad Pen Gestures Don't Work **113**

Ruled Lines on Screen Don't Match Notepad Paper 114
Computer Doesn't Beep When Drawing Straight Lines 114
Handheld Does Not Appear in Sync Partner List 115
'Error: Unable to open the port' Message 115
'Error: No port found' Message 115
SmartPad Batteries Run Down Quickly 116

Service and Support 117

Contacting Seiko Instruments 117
Purchasing Supplies 118
Repair Information for US and Canada 119
Repair Information for other Regions 120
Warranty Information 122
Other Information 125
FCC Compliance Statement 125

Index 127

Introduction

InkLink™ Handwriting System and SmartPad™, the Connected Notepad, are two technologies from Seiko Instruments that link plain paper to your computer.

Using our InkNote Manager software and an ordinary paper writing pad, the InkLink Handwriting System and SmartPad automatically link to your Pocket PC, Palm personal digital assistant, notebook, or desktop computer and store anything that you write. Whether you scribble quick notes, draw diagrams or maps, or take extensive notes at meetings, your handwritten information is transferred and stored on your handheld or desktop.

This *User's Guide* provides information about three products; InkLink, SmartPad, and InkNote Manager. You probably have two of these three; InkLink and InkNote Manager, or SmartPad and InkNote Manager. We have identified sections that only pertain to InkLink or SmartPad so you can skip information that you don't need.

Introducing the InkLink Handwriting System

The InkLink Data Clip attaches to any standard notepad. A special pen is provided, and it automatically transmits whatever you write through the IrDA transceiver to your handheld or through the USB cable to your desktop computer. For convenience, the opposite end of the pen contains a stylus point for use with the handheld.

How InkLink Works

The InkLink Data Clip continuously listens for communications from the InkLink pen. As you write with the InkLink pen on the paper pad, the InkLink Data Clip reads the location of the pen tip and communicates its exact location to your handheld or desktop.

InkLink Features

The following diagram points out the InkLink features:



InkLink Carrying Case. The InkLink carrying case protects the InkLink components you need to use InkLink with your handheld. The case is compact enough to fit into a pocket or purse.

InkLink Data Clip. The InkLink Data Clip clamps on the edge of a standard notepad and listens for communications from the InkLink pen. It communicates the location of the pen to your handheld or desktop.

InkLink Electronic Pen. The special InkLink electronic pen is used for writing on the Notepad. The InkLink pen contains a transmitter that communicates with the InkLink data clip. The InkLink pen uses ink cartridges and three SR41 button batteries that can be easily replaced.

IrDA Transceiver. The IrDA transceiver snaps onto your handheld and communicates through the infrared port. No matter where the infrared port is on your handheld, the IrDA transceiver will fit it.

Introducing SmartPad

SmartPad consists of an electronic notepad, integrated into an elegant portfolio that also stores and protects your handheld. The paper notepad is a standard-sized pad; refills are available from any office supplies store. A special pen is provided, and it automatically transmits whatever you write through InkLink and into your handheld. For convenience, the opposite end of the pen contains a stylus point for use with the handheld.

How SmartPad Works

Located beneath SmartPad's paper pad is a special digitizer tablet that is sensitive to the position of the SmartPad pen. As you write with the SmartPad pen on the paper pad, the SmartPad reads the location of the pen tip and communicates its exact location to your handheld.

SmartPad Features

The following diagram points out the SmartPad features:

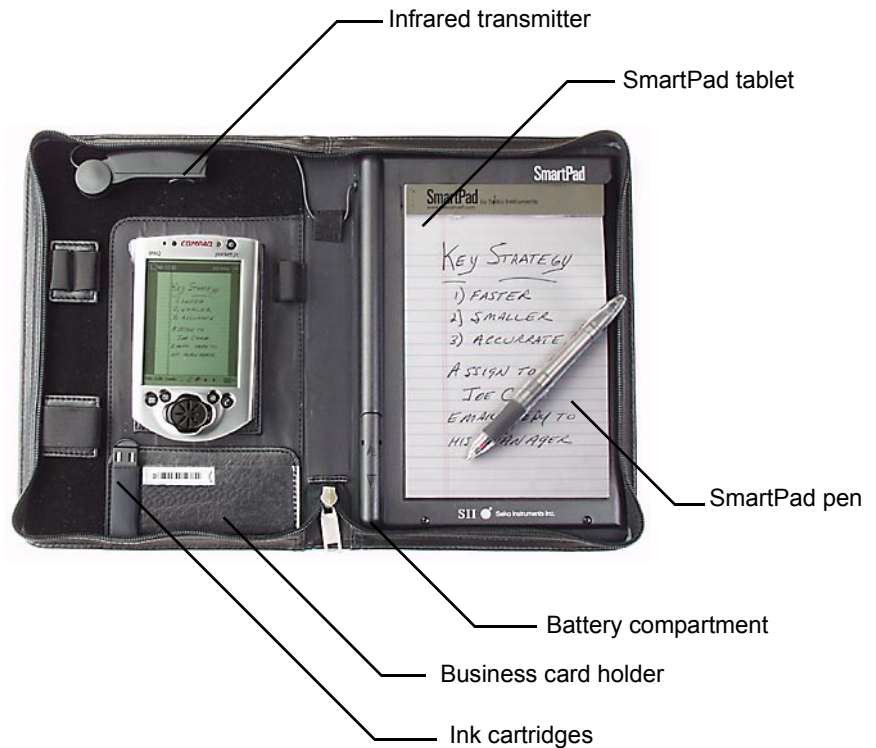

The features of the original SmartPad are quite similar. The main difference is its infrared transceiver, which is fixed at the top of the handheld. Because there is more room, the original SmartPad has an additional storage pocket.

Infrared Transceiver. The infrared transceiver communicates information between SmartPad and the handheld. There must be a clear path between this infrared transceiver and your handheld. Do not store items in the area between the infrared transceiver and the handheld.

The infrared transceiver in SmartPad 2 is on a rotating arm, which allows you to set it up for handheld models with an infrared port on the left side as well as for models with the infrared port at the top.

SmartPad Pen. The special SmartPad pen is used for writing on the Notepad. The SmartPad pen contains a transmitter that communicates with the SmartPad. The SmartPad pen uses ink cartridges and an AAAA battery that can be easily replaced.

Notepad. The Notepad is a standard-sized paper pad. Replacements for this pad are available from office supplies stores. Any standard paper pad of the correct dimensions will work just fine with SmartPad.

Battery Compartment. The battery compartment contains the two standard AAA batteries that power the SmartPad.

Business Card Holder. This pocket provides a convenient place to store business cards.

Ink Cartridges. Your SmartPad uses the special SmartPad pen for writing on the Notepad. This pocket contains spare ink cartridges for the SmartPad pen.

SmartPad 2 includes two sets of elastic loops for holding pens, phones, and other small items. You can remove these loops and place them anywhere along the top or left edge of the SmartPad (as long as you don't block the infrared transceiver).

The original SmartPad includes a storage pocket that can be used for anything that you want to carry along. Many users find it a convenient place for a cell phone.

Introducing InkNote Manager

InkNote Manager is the software that communicates with InkLink and SmartPad. It captures your handwritten notes and helps you to organize and communicate them.

InkNote Manager Software on your handheld

The InkNote Manager software installed on your handheld automatically recognizes the data transmitted by InkLink or SmartPad, and instantly creates a new ink note. You can synch ink notes with your desktop, e-mail your ink notes, or beam them to another portable device.

InkNote Manager Software on your Desktop Computer

When you synchronize your handheld with your desktop (or notebook) computer, all of your ink notes are automatically copied to the computer and saved for use by the desktop version of InkNote Manager. This software allows you to view, print, edit, and e-mail your ink notes from your desktop computer. Connect the InkLink Data Clip to your desktop and it captures your handwriting.

InkNote Manager Works the Same on Both Computers

The InkNote Manager software on your desktop computer works just like the InkNote Manager software on your handheld. When you learn how to use one, you know how to use both. There are differences, of course (for example, you can beam notes from one handheld to another), but where they share the same capabilities, they work pretty much the same.

InkNote Manager Features

Once you have installed the InkNote Manager software, InkLink and SmartPad work instantly and automatically to transfer your handwritten notes into your handheld or desktop computer. InkNote Manager features include:

Easy user interface. Just touch the pen to the pad, and you're automatically storing your handwritten data! Once you've captured the data, InkNote Manager lets you organize it for easy retrieval, edit it, copy portions to documents in other applications, and send ink notes to others via e-mail or beaming.

Multiple Pages. Each ink note can have any number of handwritten pages. With the handheld you can view the contents of each page, and make additions and changes as necessary.

Enlarged View. You can zoom to enlarge the view of the written notes on the handheld, and pan to move the position of the image on the screen. You can zoom up to 4x magnification to view the smallest details of your handwritten notes on the handheld.

Integrated Sleep. InkNote Manager's sleep mode integrates with the handheld's battery-saving features. When you use InkNote Manager's Explorer (its screen for displaying and organizing lists of ink notes), the standard handheld power-management features control the system. A separate timer that you set in InkNote Manager determines the shutoff time when you use its Note Editor (its screen for recording and modifying handwritten data). This gives you optimum power conservation without the system shutting off during short breaks between writing. In Note Editor, after the screen blanks you can wake the handheld simply by pressing the pen to the paper for a moment, and you can continue taking notes. If you don't use your InkLink or SmartPad for a longer time (the setting you make in InkNote Manager), the software turns off the infrared communications with the device and then completely turns off your handheld. To resume, press the power button. (On a Pocket PC, press the power button two times.)

Setting Up

This section explains how to install the InkNote Manager software on your desktop computer and your handheld and how to set up your InkLink or SmartPad.

- System Requirements
- InkLink Setup
- InkLink Basics
- SmartPad Setup
- Starting InkNote Manager

System Requirements

InkLink and SmartPad have the same system requirements. You need the following:

Desktop Computer

- Desktop or laptop computer with one of the following Microsoft operating systems:
 - Windows 95
 - Windows 98
 - Windows 98SE
 - Windows Me
 - Windows NT Workstation 4.0 with SP6 or later
 - Windows 2000
 - Windows XP
- System requirements:
 - 32 MB memory
 - 16 MB hard disk space
 - CD-ROM drive
 - USB or Serial port
- One of the following Pocket PC handheld devices:

Pocket PC

To use InkLink with a Pocket PC, you need:

- Pocket PC handheld device with:
 - Microsoft Windows CE 3.0, Pocket PC 2000, or later
 - 1 MB available memory
 - IrDA port
- ActiveSync 3.1 or later (version 3.5 recommended)
ActiveSync comes with a Pocket PC; you can download the latest version from Microsoft at www.microsoft.com/mobile/downloads/

Palm OS PDA

To use InkLink with a Palm OS PDA, you need:

- Palm OS handheld device with:
 - Palm OS version 3.1 or higher
 - 1 MB available memory
 - IrDA port
- HotSync Manager 4.0 or later

HotSync Manager is part of Palm Desktop and comes with a Palm OS device; you can download the latest version from Palm at

www.palm.com/software/desktop/

Software Setup

Setting up the InkNote Manager requires only a few simple steps:

- Confirm that HotSync is working if you are using a Palm OS handheld
- Confirm that ActiveSync is working if you are using a Pocket PC handheld.
- Install the InkNote Manager software

Confirming that HotSync is Working

If you use a Palm OS handheld, Palm HotSync Manager (part of Palm Desktop) must be installed prior to installing this software. InkNote Manager syncs information on the two computers by having HotSync move the files back and forth. To confirm that HotSync is installed and running properly, do the following:

1. Put your Palm OS handheld in the cradle or connect the cable.
2. Press the HotSync button on the cradle or cable.

If HotSync is not installed on both computers (or you can't get the devices to synchronize), resolve the HotSync problem before proceeding with InkNote Manager installation.

Confirming that ActiveSync is Working

If you use a Windows Pocket PC handheld, Microsoft ActiveSync (version 3.1 or later) must be installed prior to installing this software. InkNote Manager syncs information on the two computers by having ActiveSync move the files back and forth. To confirm that ActiveSync is installed and running properly, do either of the following:

- On the desktop computer, open the **Start** menu and choose **Programs, Microsoft ActiveSync**. Connect the Pocket PC and computer (via cable or infrared connection) and be sure that the display shows that the devices are "Connected" and "Synchronized." Be sure that **Files** is selected for synchronization.
- On the Pocket PC, open the **Start** menu and choose **Programs, Connections**. Connect the Pocket PC and computer (via cable or infrared connection), tap **ActiveSync**, and be sure the display shows that the devices are "Connected, up-to-date."

If ActiveSync is not installed on both computers (or you can't get the devices to synchronize), resolve the ActiveSync problem before proceeding with InkNote Manager installation.

NOTE: You must configure ActiveSync to synchronize files. To be sure ActiveSync is properly configured, on the desktop computer, open ActiveSync. Open the **Tools** menu and choose **Options**. On the **Sync Options** tab, select (put a check mark in) the **Files** check box.

Installing InkNote Manager Software

To install InkNote Manager:

1. Insert the software CD-ROM in your computer's CD drive.

2. If the setup program doesn't begin running automatically, click **Start, Run**. In the Run dialog box, type **d:\setup** (replace *d* with the drive letter of your CD drive) and then click OK.
3. Follow the on-screen instructions.
4. On Pocket PC 2002 models only, do the following:
 - On the Pocket PC, open the **Start** menu and tap **Settings**.
 - Tap the **Connections** tab.
 - Tap the **Beam** icon.
 - Clear the **Receiving** check box.

This allows InkLink or SmartPad to access the handheld's infrared port.

Setup Tips

- During setup you will be asked for the hardware serial number.
 - On InkLink, the serial number is located on the bottom of the InkLink data clip.
 - On the original SmartPad, the serial number is under the paper writing pad, in the lower-left corner.
 - On the SmartPad 2, the serial number is under the paper writing pad, in the upper-right corner.
- The first part of the serial number might already be displayed in the form. Be sure you don't repeat the first few characters.
- You might be asked for a software purchase code during setup.
 - If you purchased an InkLink Handwriting System, and have entered the hardware serial number correctly, you should not see this prompt. Click Back and correct the hardware serial number.
 - If you have a SmartPad that came with InkNote Manager software, and you have entered the hardware serial number correctly, you should not see this prompt. Click Back and correct the hardware serial number.

- If you have a SmartPad that originally supported Palm OS handhelds, and did not include InkNote Manager software, you must purchase an upgrade. Go to www.seikosmart.com to get a software purchase code.
- If you have previously purchased an upgrade to InkNote Manager, enter the software purchase code you received when you purchased the upgrade.
- If you are going to use your InkLink with a handheld, be sure to check the appropriate box so setup will install the handheld version of InkNote Manager.
- On Windows NT, 2000, or XP, you must have administrative rights to install the software.
- If you get an error during setup, disable your anti-virus program and run setup again.

InkLink Setup

Setting up InkLink requires only a few simple steps:

- Check that you received all the components
- Install the IrDA transceiver battery
- Install the InkLink pen batteries
- Connect the data clip

Product Box Contents

The shipping box for the InkLink should contain the following items:

- InkLink data clip
- InkLink electronic pen
- IrDA transceiver
- USB Cable

- InkLink carrying case
- Three silver oxide SR41 button batteries for InkLink pen
- One 1.5 volt alkaline AAA battery for the IrDA transceiver
- Ink cartridge for InkLink pen
- Quick Start Guide
- InkNote Manager software on CD-ROM

If any of these items is missing, contact the reseller where you purchased the InkLink.

Keep your InkLink away from small children. There are small parts that could present a choking hazard.

Installing the IrDA Transceiver Battery

The InkLink data clip is powered by a single AAA battery in the IrDA transceiver. (When connected to a desktop, it is powered via the cable.) To install the battery:

1. Remove the clip by sliding it away from the battery case.
2. Slide the battery cover away from the cable to remove the cover.

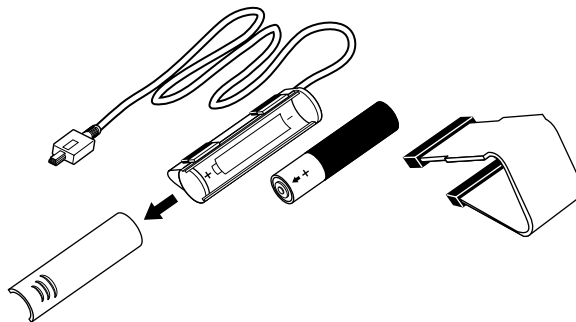

3. Insert the battery into the battery compartment. Be sure the positive (+) end of the battery points away from the cable.
4. Replace the battery cover and slide it into place.

5. Replace the clip.

Installing InkLink Pen Batteries

The InkLink pen is powered by three SR41 batteries. With regular use of your InkLink, these batteries should power the InkLink pen for several months.

To install the batteries:

1. Unscrew the battery cap from the pen.
2. Remove the three batteries. You might have to shake the pen to remove the batteries.

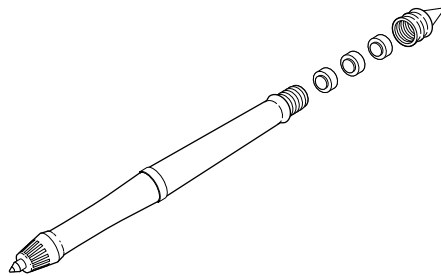

3. Insert fresh SR41 batteries. The positive (+) end of the batteries should all be facing up.
4. Screw the battery cap back on the pen.

Attaching the InkLink Data Clip

The InkLink data clip attaches to any notepad or paper. You can clip it on any side of the page that you like.

Clip the data clip on the whole pad. While you can use the data clip on a single sheet of paper, it clamps more securely on multiple sheets. If the data clip slips, and changes its position on the page, it will affect your results.

To attach the InkLink data clip:

1. Pinch the center of the back of the data clip between your thumb and first finger.

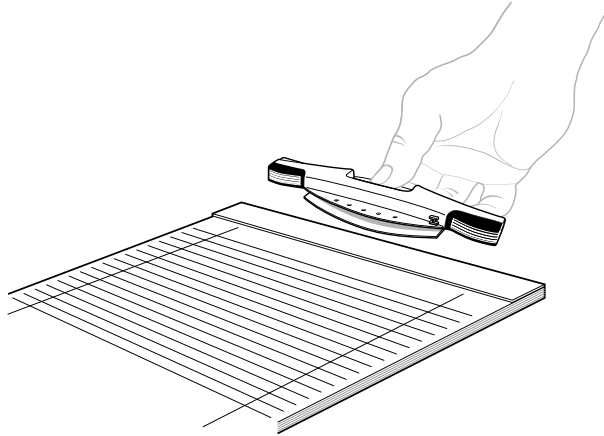

2. Place the data clip clamp over the edge of your pad, align the left sides, and release it.

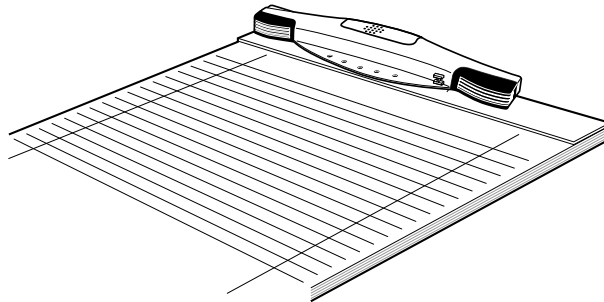

Aligning the data clip with the left edge of the paper makes it easy to put it in the same place every time.

See Also

“Defining a Paper Size” on page 49

Connecting to a Handheld

Use the IrDA transceiver to connect the InkLink data clip to a handheld device. To connect the IrDA transceiver:

1. Connect the cable on the IrDA transceiver to the connector on the left end of the data clip.
2. Place the IrDA transceiver on the edge of your handheld over the IrDA port. The positioning is flexible; it is best if it is not tight against the port. Be sure the end of the clip is not touching the screen.

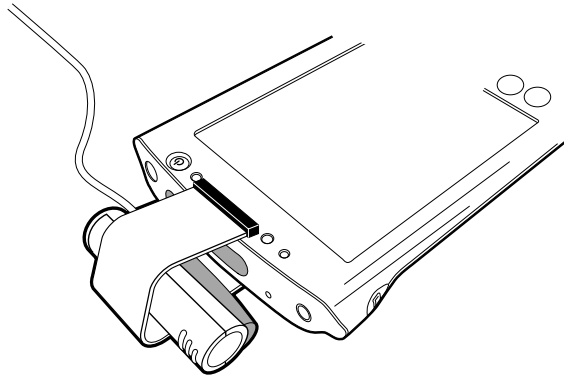

If you don't know where the infrared port is on your handheld, check your user's guide.

Connecting to a desktop

Use the InkLink USB cable, or optional InkLink serial cable, to connect the InkLink data clip to a desktop or notebook computer. To connect the cable:

1. Connect the small connector on the cable to the connector on the left end of the data clip.
2. Connect the other end of the cable to the appropriate port on the desktop or notebook computer.

USB cables can be connected and disconnected when your computer is running. You should turn your computer off before connecting or disconnecting a serial cable.

InkLink Basics

- Using the InkLink pen
- Placing InkLink in the carrying case

Using the InkLink Pen

The InkLink pen communicates continuously with the data clip. For best results:

- Keep your pen at a constant angle while you write.
- Write with even pressure on the pen.
- Leave a half inch margin next to the data clip.

The InkLink pen needs an unobstructed view of both ends of the data clip to operate correctly.

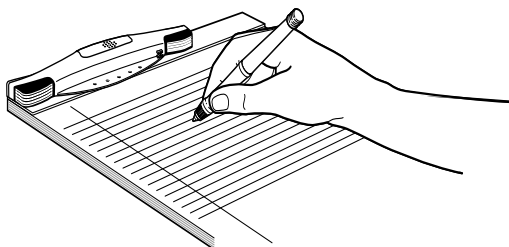

If your writing style obstructs this view, try placing the data clip on a different edge of the paper.

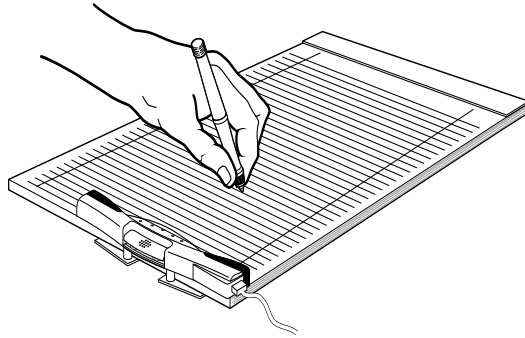

Here are examples of a few other things that might block the data clip's view of the pen:

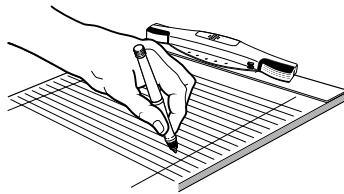

Placing an obstruction (such as a hand) between the pen and the data clip. If you write with your hand above the pen, put the data clip on a side or the bottom of the pad.

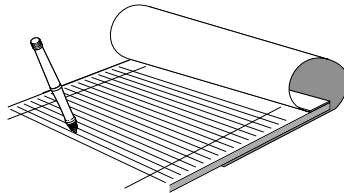

Flipping a sheet over the data clip to write on a sheet below.

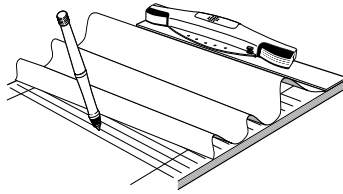

Lifting a sheet of paper to write on the bottom edge or the sheet below, or bending the writing pad or paper so the raised center of the sheet blocks the view.

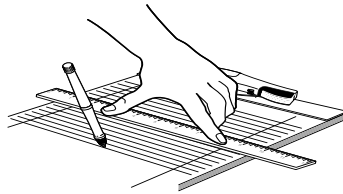

Holding a ruler between the data clip and the pen. When the data clip is at the top of the pad, draw lines on the top edge of the ruler.

Don't put the InkLink pen in your mouth. It won't work correctly if it is wet.

See Also

“InkLink ink notes do not match paper notes” on page 112

Placing InkLink in the Carrying Case

All the InkLink components you need to use InkLink with a handheld fit in the carrying case for transport.

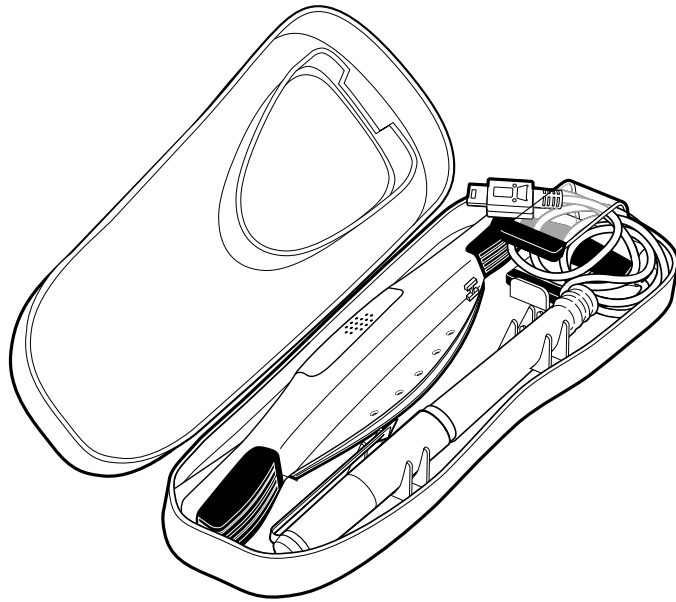

An easy way to stow the IrDA cable is to place the plug in the IrDA transceiver's clip, and then coil the cable and place it in the clip.

SmartPad Setup

Setting up the SmartPad requires only a few simple steps:

- Check that you received all the components
- Install the SmartPad portfolio batteries
- Attach your handheld to the SmartPad portfolio

Product Box Contents

The shipping box for the SmartPad should contain the following items:

- SmartPad portfolio (with paper tablet installed)
- SmartPad pen (with one AAAA battery installed)

- SmartPad pen refill cartridges (in a holder with a cartridge-replacement tool)
- Two AAA batteries for the SmartPad portfolio
- Two self-adhesive hook-and-loop strips
- Quick Start Guide
- InkNote Manager software on CD-ROM

If any of these items is missing, contact the reseller where you purchased the SmartPad.

Installing the SmartPad Portfolio Batteries

The SmartPad portfolio is powered by two AAA batteries. To install the batteries in the SmartPad portfolio:

1. Press down on the top edge of the battery cover and then slide the cover toward the bottom of the portfolio to remove the cover.

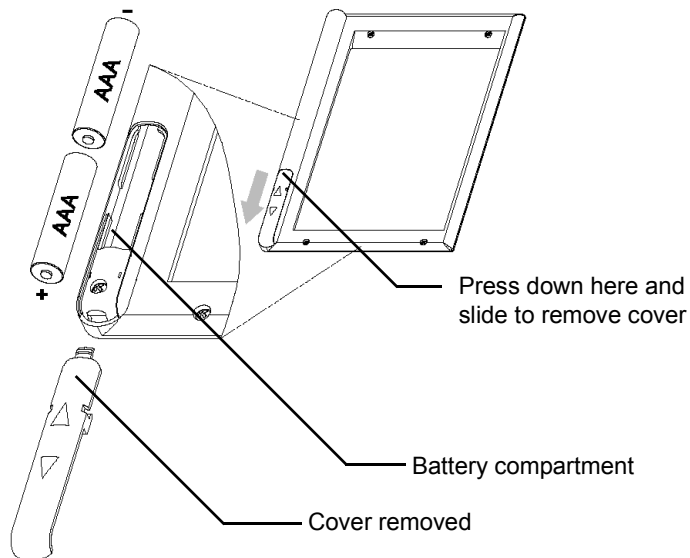

2. Insert the batteries into the battery compartment. Be sure the positive (+) end of both batteries points toward the bottom of the portfolio.

3. Replace the battery cover and slide it into place.

See Also

“Replacing the SmartPad Pen Battery” on page 101

Repositioning the Infrared Transceiver

As shipped, SmartPad 2 is set to work with handhelds that have the infrared port located on the top edge of the handheld. (The original SmartPad works only with such handhelds.) On some handhelds, the infrared port is located on the left side. To use SmartPad 2 with handhelds that have an infrared port on the left side, you must reposition SmartPad’s infrared transceiver. To reposition the transceiver:

1. Pull to remove the round cap on the transceiver.
2. With the round cap removed, pull straight up to remove the arm of the infrared transceiver from the snap retainers of the SmartPad portfolio. Be aware that a wire connects this arm to the SmartPad portfolio—take care not to pull on the wire as you remove the arm of the infrared transceiver.

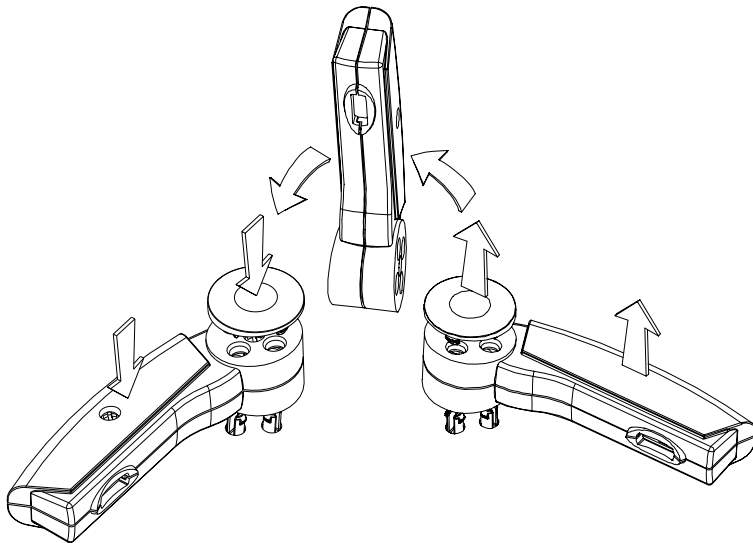

3. Turn the infrared transceiver arm over, and press it down firmly until it “snaps” into place in the new position in the SmartPad portfolio.

4. You may need to gently feed the wire of the infrared transceiver arm into the cover of the SmartPad portfolio. Be careful! You want the infrared arm to be seated firmly and securely into the SmartPad portfolio.
5. Replace the round cap to secure the arm of the infrared transceiver.

Attaching Your handheld

Your handheld must be placed in the designated area of the SmartPad portfolio so the infrared ports of the two devices can communicate properly. Two self-adhesive strips of hook-and-loop material keep the handheld securely in place.

The hook-and-loop material provides an extremely aggressive bond. That's terrific if you plan to leave your handheld in the SmartPad portfolio nearly all the time. But if you expect to frequently remove and replace the handheld from the portfolio, we suggest you use only half of the self-adhesive loop material, as follows:

1. Without separating the backing strips, remove the two loop strips from the portfolio's hook strips to which they're attached.
2. Cut one of the strips in half lengthwise. Save the other strip for future use.
3. Replace the two half strips on the portfolio's matching hook material.
4. Continue with the following procedure.

To attach the handheld:

1. Remove the backing from the self-adhesive strips in the SmartPad portfolio.
2. Place the handheld on the strips, centering it on the pad area to which the hook-and-loop strips are attached.

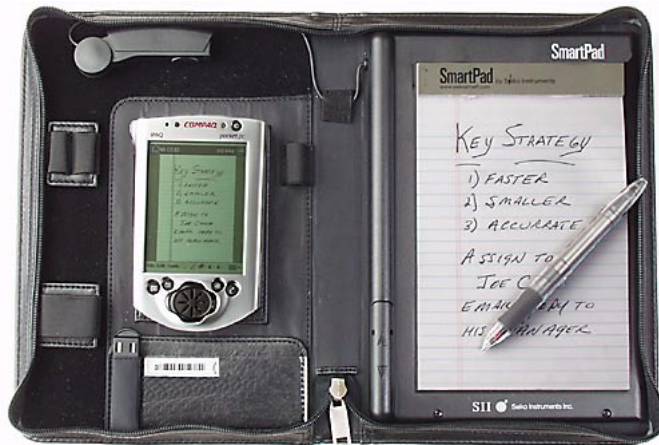

3. Press firmly to adhere the strip to your handheld.
4. Remove your handheld from the SmartPad, turn the handheld over, and press the loop strips so that they're securely, permanently adhered.

Starting InkNote Manager

Once InkLink or SmartPad is assembled, it's time to start the InkNote Manager software.

- Starting InkNote Manager on a Pocket PC
- Starting InkNote Manager on a Palm
- Starting InkNote Manager on a desktop computer
- Selecting a handheld as a Partner

Starting InkNote Manager on a Pocket PC

After your handheld is connected, you should run InkNote Manager on the handheld. This establishes communication between the handheld and the device. To start InkNote Manager:

1. Tap the **Start** menu and choose **InkNote Manager**.

2. Write on the tablet with the pen. An ink note will appear on the Pocket PC's screen.

If an ink note does not appear, follow the procedure detailed in the topic below.

See Also

“Testing the handheld and InkLink or SmartPad” on page 110

Starting InkNote Manager on a Palm OS handheld

After your Palm handheld is connected, you should run InkNote Manager on the handheld. This establishes communication between the handheld and the device. To start InkNote Manager:

1. Tap the **Home** icon.
2. Tap the **InkNote Manager** icon.
3. Write on the tablet with the pen. An ink note will appear on the handheld's screen.

If an ink note does not appear, follow the procedure detailed in the topic below.

See Also

“Testing the handheld and InkLink or SmartPad” on page 110

Starting InkNote Manager on a Desktop computer with InkLink

After your desktop computer is connected, you should run InkNote Manager on the desktop computer. This establishes communication between the desktop and the InkLink data clip. To start InkNote Manager:

1. On your desktop computer, double-click the **InkNote Manager** icon on the desktop. (Alternatively, open the **Start** menu and choose **Programs, InkNote Manager, Run InkNote Manager.**)

2. In InkNote Manager, open the **Setup** menu and choose **Tablet Properties**.
3. From **Available Ports**, choose the port to which you connected the InkLink cable. Click **OK**.
InkNote Manager remembers this setting. You only need to do this once.
4. Write on the InkLink tablet with the InkLink pen. An ink note will appear on the screen.

If an ink note does not appear, follow the procedure detailed in the topic below.

See Also

“Testing the handheld and InkLink or SmartPad” on page 110

Selecting a handheld as a Partner

If you have only one handheld that you synchronize with your desktop computer, you’re all set and you can skip this step.

If you have set up partnerships with more than one handheld, however, you must select the one that you’ll use with InkNote Manager. To select a partner device:

1. On your desktop computer, double-click the **InkNote Manager** icon on the desktop. (Alternatively, open the **Start** menu and choose **Programs, InkNote Manager, Run InkNote Manager.**)
2. In InkNote Manager, open the **Setup** menu and choose **Select Sync partner**.
3. Select the name of your handheld from the list and then click **OK**.

InkNote Manager thereafter uses as a default storage location for ink notes, a folder that is synchronized between your desktop and handheld computers.

See Also

“Using InkNote Manager with Multiple handheld Devices” on page 95

Getting Started

InkNote Manager has two basic views:

- Explorer is a file manager that lists the ink notes you have created. It's the launch point for creating new ink notes, and it provides various methods for finding existing ink notes.
- Note Editor displays a page of an ink note, and enables you to view, modify, and work with an ink note in various ways.

This section provides an introduction to the two views, and also explains how to obtain help.

Explorer

When you start InkNote Manager, it initially displays its Explorer, the tool that allows you to organize and retrieve your ink notes. The Explorer in the desktop version of InkNote Manager is nearly identical to that of the handheld versions.

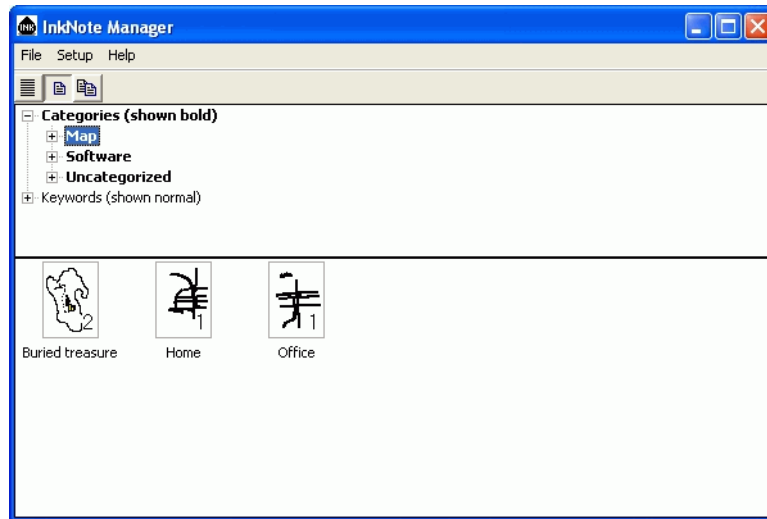

Desktop

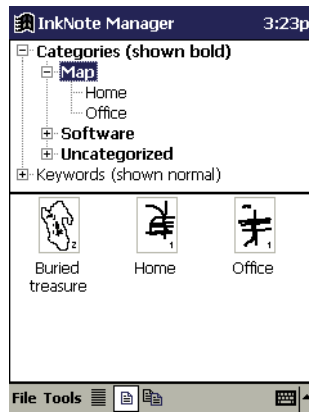

Pocket PC



Palm

Explorer automatically manages all ink notes that you create with InkNote Manager. In Explorer, you use the top part of the window to select a category or keyword. (You can assign categories and keywords to each ink note.) The bottom part of the window displays all the ink notes with the category or keyword you select.

When you find the ink note you want, tap or double-click its name or icon; it then opens in Note Editor.

See Also

“Creating an Ink Note” on page 50

“Finding an Ink Note in Explorer” on page 57

“Changing Explorer Views” on page 58

“Setting Up Categories” on page 62

Note Editor

Note Editor appears when you create a new ink note and when you open an existing one. It mirrors the information that you write on the notepad, and it also provides tools for modifying ink notes.

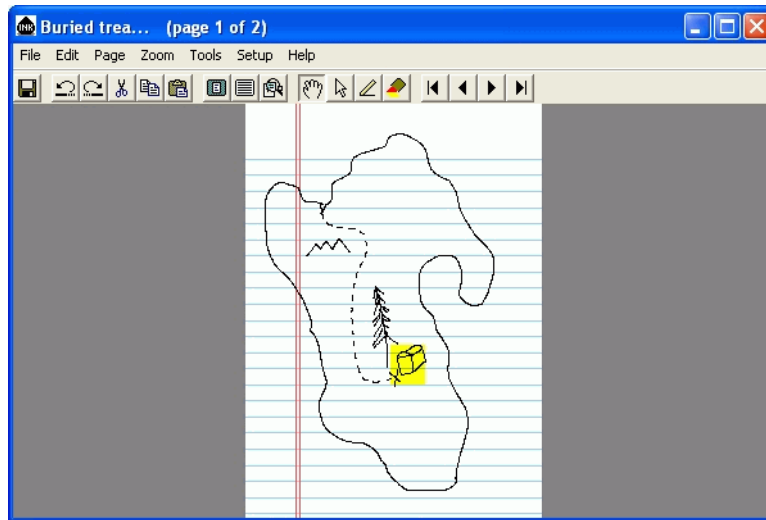

Desktop

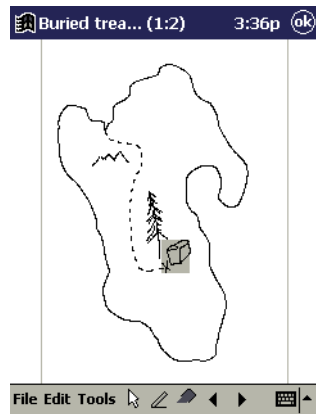

Pocket PC

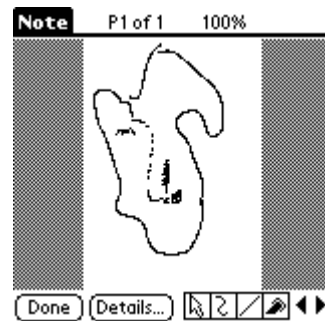

Palm

You switch to Note Editor by opening an ink note in Explorer. InkNote Manager also switches from Explorer to Note Editor automatically when you begin writing on the notepad.

To return to Explorer, in Note Editor tap **OK**, or **Done**, or open the **File** menu and choose **Exit**.

See Also

“Creating Ink Notes” on page 47

“Editing Ink Notes” on page 65

Help

In addition to the *Quick Start Guide*, several online resources are available:

- The *User’s Guide* is an Acrobat PDF document that contains detailed information about the hardware and the InkNote Manager software.
- Online help for the desktop version of InkNote Manager contains detailed information about using the software on your desktop computer.
- Online help for the Pocket PC version of InkNote Manager contains information you might need while away from your desktop computer, including detailed procedures for using the software on your Pocket PC and for replacing the batteries and ink cartridges.
- Online help for the Palm version of InkNote Manager contains tips and troubleshooting information that you might need while away from your desktop computer.
- The Web site for Seiko Instruments (www.seikosmart.com) provides answers to frequently asked questions, software updates, replacement parts and supplies, and other support information.

Getting Help

To view the *User’s Guide* on your desktop computer:

- Open the **Start** menu and choose **Programs, Seiko InkNote Manager, View User Guide**. (To view the *User’s Guide*, you must have Adobe Acrobat Reader installed on your computer. You can install it from the CD, or you can download it from www.adobe.com.)

To view online help for the desktop version of InkNote Manager, do either of the following:

- Open the **Help** menu and choose **Help Contents**.
- Press F1.

To view online help for the Pocket PC version of InkNote Manager, do either of the following:

- Open the **Start** menu and choose **Help**.
- Open the **File** menu and choose **Help**.

To view online help for the Palm version of InkNote Manager, do either of the following:

- Open the **File** menu and choose **Help**.
- Open the **Note** menu and choose **Help**.

Creating Ink Notes

The documents you create and manage with InkNote Manager are called *ink notes*. In this section, we explain how to:

- Select a paper size
- Define a paper size
- Create an ink note
- Add a page to an ink note
- Save an ink note
- Delete an ink note
- Export an ink note for use with another program
- Close Note Editor

Ink Notes

Ink notes are document files used by InkNote Manager; they're an electronic representation of the images you create using the ink pen provided with your device. An ink note can contain multiple pages.

Ink notes can contain *ink* (lines) that you create using the ink pen, the stylus provided with your handheld, or a mouse or other pointing device connected to your desktop computer. Ink notes can also contain *highlights* (colored rectangles) that you can use to emphasize certain areas in much the same way you'd use a yellow highlighter pen. Ink and highlights can be created in any of seven colors.

See Also

“Working with Ink Notes” on page 66

Selecting a Paper Size

InkNote Manager needs to know what size the page is on which you are writing. Selecting a paper size tells the software what size the page is as well as where the data clip is placed in relation to the page.

To set the paper size:

1. In Explorer, open the **Setup** menu and choose **Preferences**.
2. In **Default note size**, choose the paper size you want to use.

The pre-defined paper sizes assume that the data clip is placed on the top edge of the paper and aligned with the left edge of the page. If you prefer to use a size of paper that is not listed, or to place the data clip in a different position, you need to re-define the paper size to suit your needs.

See Also

“Defining a Paper Size” on page 49

Defining a Paper Size

If you prefer to place the data clip in a position different from on the top edge, left-aligned, then you need to re-define a paper size to suit your use.

You can place the data clip on any edge of the page, and use paper up to legal size (8-1/2" x 11") in portrait and up to letter size (11" x 8-1/2") in landscape. Use this procedure to tell InkNote Manager how big the page is, and where the data clip is place. All it takes is two taps of the pen.

The paper sizes listed in InkNote manager are simply labels for the paper size definitions. You can redefine any listed size to any size of paper. There are two items in the list that are designed for use with your special sizes of paper: Custom 1 and Custom2.

- If you are putting the data clip on the short edge of the page, we recommend you place it at the corner. This makes it easy to put the data clip in the same position on another page.
- If you are putting the data clip on the long edge of the paper, we recommend you place it in the center. This ensures that the InkLink will produce the best results over the entire page.

To define a paper size:

1. Place the data clip in the position in which you are going to use it on the page.
2. In Explorer, open the **Setup** menu and choose **Paper Size**.
3. Choose the paper size that you want to re-define.
4. Click the InkLink pen in the upper-left corner of the page, staying at least 1/2" from the data clip. Click **Next**.
5. Click the InkLink pen in the lower-right corner of the page, staying at least 1/2" from the data clip. Click **Next**.
6. Tap **OK**.

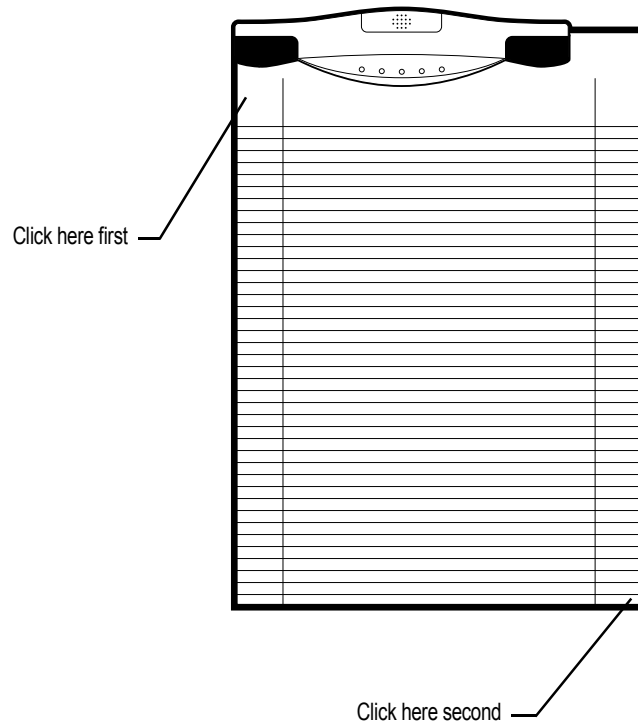

Creating an Ink Note

To create a new ink note, do one of the following:

- In Explorer, open the **File** menu and choose **New**.
- On a Palm, in Explorer, click **New**.
- While Explorer is displayed, begin writing on the paper pad.

Adding a Page

To add a page to an ink note, do any of the following:

- Tap the **Next Page** button, shown below. (This works only if the last page in the ink note is not blank.)



- On SmartPad, press and hold the SmartPad pen for a few moments in the lower right corner of the page, until the handheld beeps.
Using this gesture allows you to take notes without having to tap the handheld screen. You can focus on using the inking pen and working only on the paper. Although the pen leaves a mark on the paper, InkNote Manager removes the mark from the ink note as it is stored in memory.
- On a desktop or Pocket PC, open the **Edit** menu and choose **Insert Page**.
- On a Palm, open the **Page** menu and choose **Insert Page**.

Note that the first two methods append a page after the last page. (If the last page is not currently displayed, these techniques display the next page instead of adding a new page.) The Insert Page command inserts a page before the currently displayed page.

Saving an Ink Note

On a Palm, ink notes are saved automatically. On a desktop or Pocket PC, follow this procedure.

To save an ink note:

1. In the Note Editor, open the **File** menu and choose **Save**.
2. Specify a file name if you don't want to use the default name. Ink notes are saved with a .ink extension, which is appended automatically.
3. Select the folder where you want to save the file. All folders in the list are subfolders of My Documents; selecting **None** saves the file in the My Documents folder.

See Also

“Setting the Default File Name” on page 90

Deleting an Ink Note

To delete an ink note on a desktop:

- In Explorer, right-click the ink note you want to delete. (To select more than one ink note, drag a lasso around the ink notes, or hold Ctrl as you click each one. Then right-click one of the selected ink notes.)
4. In the shortcut menu, choose **Delete**.

To delete an ink note on Pocket PC:

1. In Explorer, tap and hold the ink note you want to delete. (To select more than one ink note, drag a lasso around the files.)
2. In the shortcut menu, choose **Delete**.

To delete an ink note on a Palm:

1. In the **File** menu, choose **Delete Notes**.
2. Tap the note you want to delete.
3. Tap **Delete**.

Exporting an Ink Note

On a desktop or Pocket PC, you can save notes you create with InkNote Manager in formats that can be edited and used with other programs. When you export a note, each page is saved as a separate file. To export a note:

1. In the Note Editor, open the **File** menu and choose **Export**.

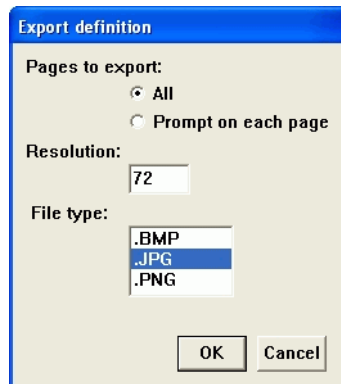

2. Specify whether you want to export all pages of the note—each as a separate file—or be prompted whether to export each page individually.

3. Specify a resolution, in dots per inch, for the exported file. The value to use here depends on the program in which you plan to use the exported file. Higher values produce sharper images, but larger files. Higher values also use more memory. If you get a “Cannot complete process” error, try a lower resolution. With sufficient memory, values from 50 to 600 dpi are appropriate.
4. Select a file type from the following choices:
 - *.BMP*. Bitmap graphics files (.bmp file name extension) can be edited with Microsoft Paint and can be embedded in most types of documents.
 - *.JPG*. Files in Joint Photographic Experts Group format (.jpg file name extension) are considerably smaller than bitmap graphics files and are more versatile. They can be edited with most graphics-editing programs and can be embedded in most types of documents, including HTML documents (Web pages).
 - *.PNG*. Portable Network Graphics files (.png file name extension) can be edited with most modern graphics-editing programs. They can be used as images in HTML documents (Web pages), but only newer Web browsers can display them properly.
5. Click **OK**.
6. Specify a file name if you don’t want to use the default name. InkNote Manager appends an underscore (_), a letter *p*, and a sequential page number to each file that’s generated. For example, if you specify “Kitchen Plans” as the file name for an export in bitmap format, the first page would be saved as Kitchen Plans_p1.BMP, the second page as Kitchen Plans_p2.BMP, and so on.
7. Select the folder where you want to save the file. All folders in the list are subfolders of My Documents; selecting **None** saves the file in the My Documents folder.

See Also

“Setting the Default File Name” on page 90

Closing Note Editor

When you're through editing a note, you can close Note Editor and return to Explorer in any of the following ways:

- Tap **OK** or **Done**.
- Click the close button in the upper right corner of the window.
- Open the **File** menu and choose **Exit**.
- On SmartPad, press and hold the SmartPad pen for a few moments in the upper left corner of the page, until the handheld beeps.

Using this gesture allows you to take notes without having to tap the handheld screen. You can focus on using the inking pen and working only on the paper. Although the pen leaves a mark on the paper, InkNote Manager removes the mark from the ink note as it is stored in memory.

See Also
“Using Pen Gestures on SmartPad” on page 70

Organizing and Finding Ink Notes

Why Organize?

Many people take copious notes. Unfortunately, writing notes doesn't make you organized. The thing that separates note takers from organized people is how they manage to find information that they have stored.

The greatest strength of InkNote Manager is its ability to retrieve information. Although InkNote Manager provides good tools to capture and edit handwritten information, the thing that sets it apart is its Explorer and the way it allows you to easily find information.

InkNote Manager allows you to capture the information in an ink note and then close and save the ink note. (You can give it a name if you want, or accept the proposed default name.) Later, when you are organizing your thoughts and notes, you give InkNote Manager some clues about the information in the ink note. The result is that when you want to find and view information in the future, you use the tools in InkNote Manager Explorer to quickly locate the information you need.

In general, you take the steps outlined in the following example to effectively use InkNote Manager:

1. *Capture.* During your work day, you might dash from one meeting to another, taking notes at each one. Using InkNote Manager, you do the same as you would with pen and paper, except that you break your notes into ink note files. For example, if you take three pages of notes in the first meeting, you would save those notes in one ink note file having three pages.
2. *Organize.* The next step is the one that will make you organized. You go through each ink note and give InkNote Manager clues about the information.
 - You tell InkNote Manager to what category or categories the ink note belongs. (You can associate an ink note with multiple categories, which effectively allows you to store the note in several places at once.)
 - You can select keywords in an ink note and use the handheld's built-in character recognition to read them and store them as clues. You can also enter keywords manually.
 - You can give a meaningful file name to each ink note instead of using the default name.
 - On a desktop or Pocket PC, you can add action items to your to-do list as Outlook tasks.
 - You can highlight (as with a yellow highlighter pen) parts of your ink notes or change the color of important sentences. These changes will be easy to spot in thumbnail views of ink notes.
3. *Search.* Later, when you want to find information, you use InkNote Manager's Explorer. Explorer provides a variety of tools and views for quickly finding the information you want. For example, you can list all the ink notes that are stored in a certain category, all the ink notes that have a certain keyword, or all the ink notes that are both in a given category and have a certain keyword. You can display the list in any of three views:
 - Detail view shows the file name, size, creation date, and last modification date for each ink note in the list. You can sort the list on any

column. For example, you might sort on modified date to find recently changed ink notes.

- Thumbnail view (first page only) shows a thumbnail-sized representation of the first page of each ink note in the list. A number in the lower right corner of the thumbnail indicates the number of pages in the note.
- Thumbnail view (all pages) shows a thumbnail image of every page of every ink note in the list. Using this view, you can find a note if you remember what it looks like.

Except for using character recognition to enter keywords, you can perform all of these steps on the handheld or on your desktop computer. InkNote Manager has similar capabilities on both platforms.

Finding an Ink Note in Explorer

To find an ink note, work in Explorer's tree pane (the top part of the screen).

To find an ink note on a desktop or Pocket PC:

1. Click a plus sign to expand a branch of the tree, or click a minus sign to collapse a branch.
2. When the category or keyword in which you're interested appears, click it to select. Ink notes that have the selected category or keyword (or both, if you're looking at a keyword within a category or a category within a keyword) appear at the bottom of the screen.
3. Select a view for the list pane and then scan the list pane for the ink note you want.

To find an ink note on a Palm:

1. Select a **Category** and/or **Keyword**. Ink notes that have the selected category or keyword (or both, if you're looking at a keyword within a category or a category within a keyword) appear at the bottom of the screen.

2. Select a view for the list pane and then scan the list pane for the ink note you want.

See Also

“Changing Explorer Views” on page 58
 “Opening an Ink Note” on page 66

Changing Explorer Views

When you select a category or keyword of interest in the tree pane (at the top of the screen), all the ink notes that meet the criteria you select appear in the list pane (at the bottom of the screen). The list pane can be displayed in any of three views:

- *Detail view.* Ink notes are initially sorted by name. You can sort the list on any column by clicking the column heading. Click the column heading again to reverse the sort order.

Note name	Size	Create date	Last change date
Buried treasure	11290	2001 09/25 AM 11:25	2001 10/10 PM 06:42
D2	2264	2001 09/27 PM 05:12	2001 10/06 AM 00:16
Home	6944	2001 10/08 PM 04:16	2001 10/08 PM 11:19
N1	1842	2001 09/26 PM 02:49	2001 09/28 AM 00:08
N2	4014	2001 09/27 PM 02:40	2001 09/27 PM 10:53
N3	5474	2001 09/27 PM 04:59	2001 10/08 PM 03:57
N4	1843	2001 10/08 PM 05:14	2001 10/09 PM 10:23
N5	4013	2001 09/27 PM 02:40	2001 09/27 PM 10:53
N6	4013	2001 09/27 PM 02:40	2001 09/27 PM 10:53
N7	6011	2001 10/10 AM 11:43	2001 10/10 PM 09:13
N8	7481	2001 10/10 PM 02:46	2001 10/10 PM 09:48
Office	5565	2001 10/08 PM 04:19	2001 10/10 PM 10:18
Windows versions	7120	2001 09/25 AM 11:29	2001 09/25 PM 06:33

- *Thumbnail view (first page only).* Thumbnail images of the first page of each ink note are sorted by name.

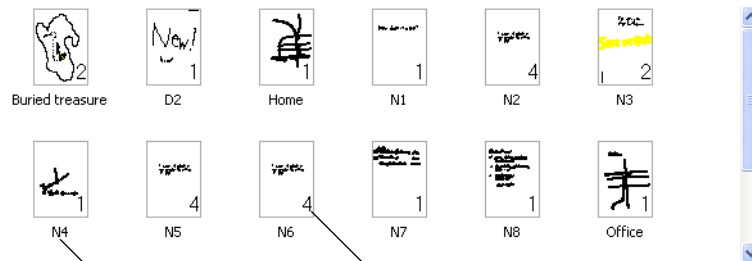

Note name

Number of pages in note

- *Thumbnail view (all pages)*. Thumbnail images of each page are sorted by last change date, with the most recent notes shown first.

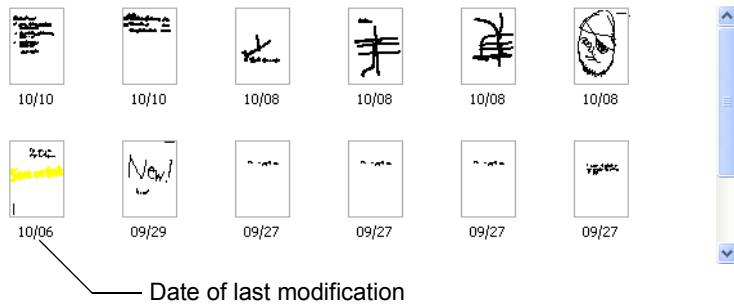

To switch between views, click one of the toolbar buttons, shown below.

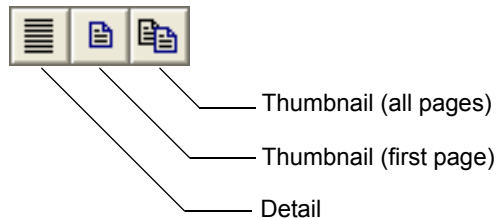

Assigning Categories and Keywords

Categories and keywords provide a powerful way to organize ink notes. Because you can associate an ink note with multiple categories and multiple keywords, you can find the ink note in any of several places and you can easily store ink notes that cover more than one topic. This is much more flexible than simply using folders to organize notes.

You might want to set up a category for each of your projects and recurring events. By default, InkNote Manager uses the categories defined in Microsoft Outlook in addition to any you define in InkNote Manager.

To assign categories and keywords to a note on a desktop or Pocket PC:

1. In Explorer, right-click an ink note and choose **Organize notes** from the shortcut menu. If the ink note is already open in Note Editor, open the

File menu and choose **Organize notes**. The Properties dialog box appears.

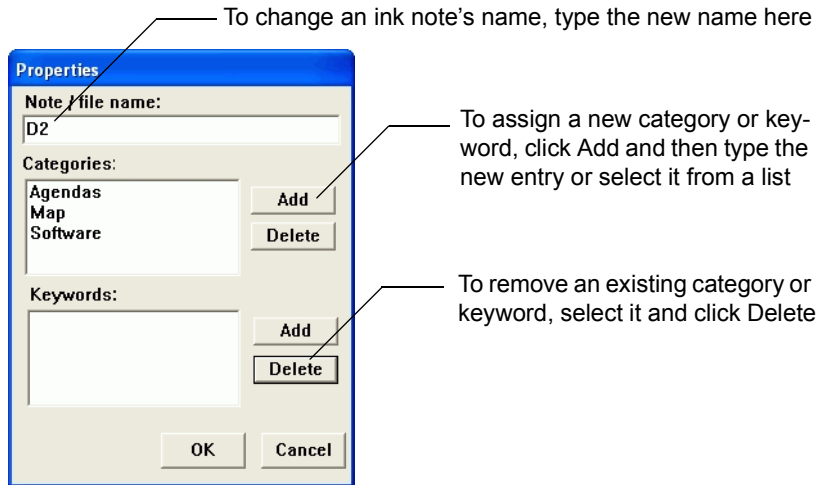

2. Click the Add button next to the Categories box or the Keywords box.

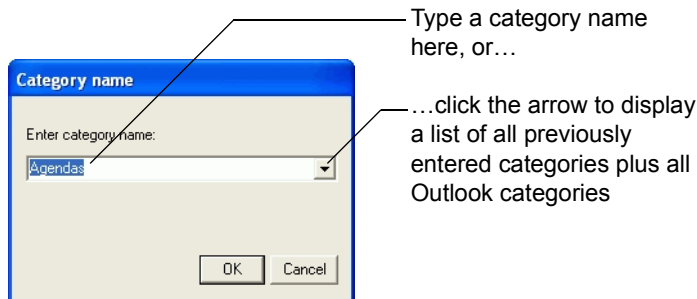

3. Type a category name or keyword. If you're assigning a category, you can select from a list instead of typing.

To assign categories and keywords to a note on a Palm:

1. In Note Editor, tap **Details**.
2. The Properties dialog box appears.

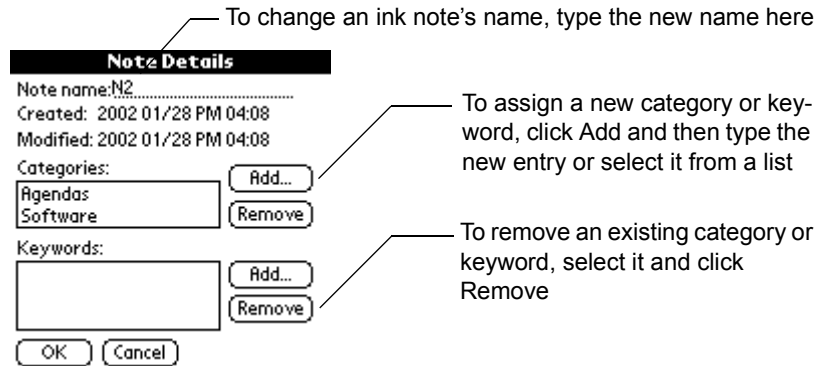

3. Click the Add button next to the Categories box or the Keywords box.

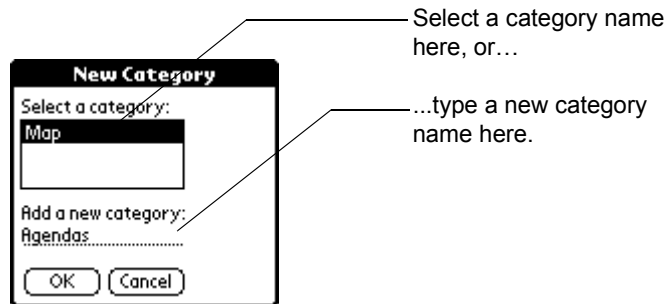

4. Type a category name or keyword. If you're assigning a category, you can select from a list instead of typing.

On a Pocket PC, you can use its character recognition capability to create keywords automatically from an ink note's content. To add a keyword based on note content:

1. In Note Editor, select the word you want to use as a keyword.
2. Open the **File** menu and choose **Recognize keywords**.
3. After the text is drawn and recognized, edit the text if necessary, and then tap **OK**.

See Also

"Selecting Parts of an Ink Note" on page 76

Setting Up Categories

InkNote Manager develops a list of categories. When you want to assign a category to an ink note, you can simply select a category from the list. The category list has two sources:

- *Categories from Microsoft Outlook.* To view Outlook categories, select any item (such as an e-mail message or contact) in Outlook, open the **Edit** menu, and choose **Categories**. You can add or delete items in Outlook's category list by clicking **Master Category List**.
- *Categories you enter.* Each new category you assign to an ink note is added to the list.

If you don't use Microsoft Outlook or you don't want to use its categories, you can prevent InkNote Manager from searching for and including those categories, as follows:

1. On a desktop or Pocket PC, display Explorer in InkNote Manager.
2. Open the **Setup** menu and choose **Preferences**.
3. Clear the **Get categories from Outlook** check box.

See Also

"Assigning Categories and Keywords" on page 59

Renaming an Ink Note

You can change the file name of an ink note in any of several ways

To change the file name on a desktop or Pocket PC do any of the following:

- In Explorer, right-click an ink note and choose **Rename** or **Organize notes**. (The latter command lets you change categories and keywords in addition to the file name.)
- In Note Editor, open the **File** menu and choose **Organize notes**.
- In Note Editor, open the **File** menu and choose **Save As**. (This method saves the ink note under a new name and also retains the original note.)

To change the file name on a Palm do any of the following:

- In Note Editor, tap Details.
- In Note Editor, open the Note menu and choose Copy Note. (This method saves the ink note with the word “Copy” appended to its name.)

Creating an Action Item

On a desktop or Pocket PC you can link ink notes to Outlook tasks, enabling you to incorporate your notes into your to-do list. The task appears in the Tasks application on the handheld and in Microsoft Outlook on your desktop computer.

To create an action item:

1. Display the note in Note Editor.
2. (Optional) Select the text that you want to be used as the subject line for the action item. (InkNote Manager uses the handheld’s character recognition capability to convert the handwriting to text, which it enters in the **Subject** box. This capability is not available on desktop versions of Windows.)
3. Open the **File** menu and choose **Register note as action item**.
4. Enter text in the **Subject** box (or confirm the text that InkNote Manager has entered) and click **OK**.

To view an action item on your handheld:

1. Open the **Start** menu and choose **Tasks**.
2. Tap the task name to open the action item.

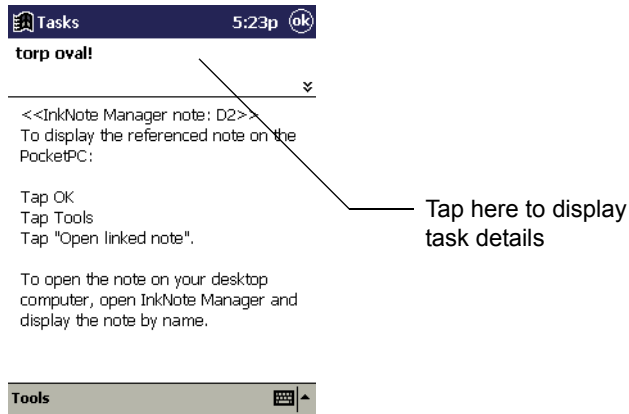

3. Tap in the top part of the task to display the task details. On the screen that appears, you can specify priority, due date, and other items; set up a reminder; and so on.
4. To display the associated ink note, tap **OK** to close the task. Then, while the task is highlighted in the main Tasks window, open the **Tools** menu and choose **Open linked note**.

If you don't need to open the task to set other details, you can open the linked note directly. In the main Tasks window, tap and hold the task name. Then choose **Open linked note** from the shortcut menu.

Editing Ink Notes

In this section we explain how to modify ink notes, the documents you create and manage with InkNote Manager. Specifically, we explain how to:

- Open an ink note
- Zoom and pan within an ink note
- Navigate between pages
- Using the pen function keys
- Use pen gestures
- Display or hide ruled lines
- Add lines to an ink note
- Draw Straight Lines
- Straightening Existing Lines
- Add highlights to an ink note
- Specify colors for lines and highlights
- Select parts of an ink note
- Cut or copy selected parts to the Clipboard

- Move selected parts
- Group parts of an ink note
- Undo edits
- Using Handwriting Recognition

Working with Ink Notes

When you work in Note Editor, you'll be in one of four modes: pan and zoom, select, write, or highlight. You select a mode by clicking its corresponding toolbar button, shown below. A depressed toolbar button indicates the currently selected mode.

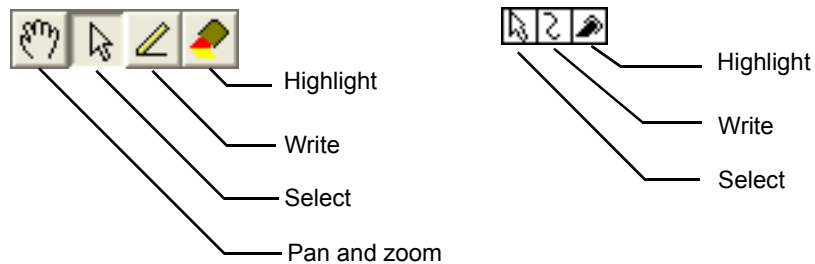

The **Pan and zoom** tool doesn't appear in the handheld application. To select this mode, tap the currently selected mode. When pan and zoom is selected, no toolbar buttons are depressed.

Opening an Ink Note

To open an ink note, do any of the following:

- In InkNote Manager's Explorer, tap or double-click the ink note you want to open.
- On a desktop or Pocket PC, in InkNote Manager's Explorer, open the **File** menu and choose **Open**. Select the folder that contains the ink note

you want to open, and then tap the ink note you want to open. (If you select **All Folders** in the **Folder** list, InkNote Manager displays all ink notes in the My Documents folder and all its subfolders.)

- In File Explorer, navigate to the ink note you want to open. (By default, ink notes are stored in the My Device\My Documents\Seiko Ink Notes folder.) Tap the ink note you want to open.
- In Windows Explorer, navigate to the ink note you want to open. (By default, ink notes are stored in the My Documents\Pocket_PC My Documents\Seiko Ink Notes folder.) Double-click the ink note you want to open.

Zooming and Panning

When you have an ink note open in the Note Editor, you can zoom in for a magnified look at your note. Once zoomed in, you can pan (that is, move up, down, left, or right) to the area of interest.

To zoom in or out using the handheld application, do either of the following:

- Be sure that none of the tools is selected (if one is selected, tap it to deselect it) and then tap the image area of the ink note. This action zooms in or, if it was already zoomed in, zooms out, toggling between Normal zoom (in which the full page fits on the screen) and either 200% or 400% zoom (whichever was last used).
- Open the **Tools** menu and choose **Zoom Normal**, **Zoom 200%**, or **Zoom 400%**.

To zoom in or out using the desktop application, do any of the following:

- Be sure the **Pan and zoom** tool (shown below) is selected. Then click the image area of the ink note. This action zooms in or, if it was already zoomed in, zooms out, toggling between Normal zoom (in which the full page fits in the Note Editor window) and either 200% or 400% zoom (whichever was last used).



- Click one of the zoom tools.

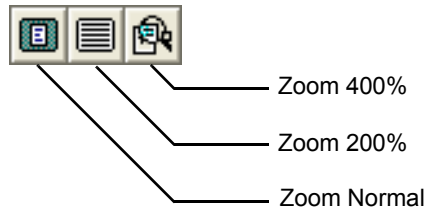

- Open the **Zoom** menu and choose **Normal**, **200%**, or **400%**.

Note that you can change the size of the Note Editor window; the image scales to fit the window.

To pan while the ink note is zoomed in, do either of the following:

- In the handheld application, be sure that none of the tools is selected. In the desktop application, select the **Pan and zoom** tool. Then drag the image in the direction you want to move.
- On a desktop or Pocket PC, use the scroll bars in any of the following ways:
 - Drag the scroll box until the part of the image you want to see is displayed.
 - Click between the scroll box and a scroll arrow to move in large steps.
 - Click a scroll arrow to move in small steps.

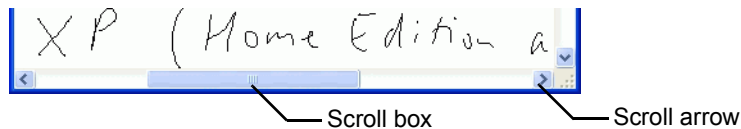

Navigating Between Pages

The title bar in Note Editor shows the number of the current page and the total number of pages in the ink note. To navigate between pages, click the **Go to previous page** or **Go to next page** tool, shown below.

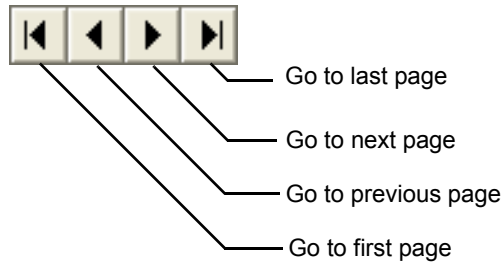

To jump immediately to the first or last page in the handheld application, open the **Edit** or **Page** menu and choose **Go to first page** or **Go to last page**. In the desktop application you can also click the **Go to first page** or **Go to last page** tool.

See Also

“Adding a Page” on page 50

“Using Pen Gestures on SmartPad” on page 70

Using the Pen Function Keys

There are five pen function keys on the InkLink data clip. You can set the function that occurs when you tap your pen in these pen function keys.

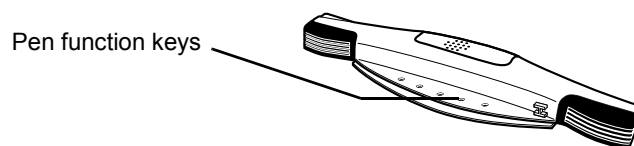

The default pen function key settings for Explorer are:

- Help
- Assign PF Keys
- Calibrate paper size
- Note thumbnail view
- Details view

The default pen function key settings for Note Editor are:

- Save
- Undo
- Previous page
- Next page
- Close note

To set a pen function key on a desktop or Pocket PC:

1. In Explorer, open the **Setup** menu and choose **Pen Function Keys**.
2. Tap the PFkey you want to set.
3. From **Explorer Action**, choose the function you want for that PFkey in Explorer.
4. From **Editor Action**, choose the function you want for that PFkey in Note Editor.

To set a pen function key for Explorer on a Palm:

1. In Explorer, open the **Setup** menu and choose **Pen Function Keys**.
2. Select the function you want for each function key.

To set a pen function key for Note Editor on a Palm:

1. In Note Editor, open the **Tools** menu and choose **Pen Function Keys**.
2. Select the function you want for each function key.

Using Pen Gestures on SmartPad

As an alternative to tapping toolbar buttons or menu commands, you can navigate between pages or close Note Editor by using the SmartPad pen. This feature allows you to work exclusively on the paper without having to tap the handheld screen.

- Press and hold the pen in the lower left corner of the paper notepad to go to the previous page. (If the first page of an ink note is displayed, nothing happens.)

- Press and hold the pen in the lower right corner to go to the next page. (If the last page of an ink note is displayed, InkNote Manager appends a new, blank page.)
- Press and hold the pen in the upper left corner to close Note Editor and return to Explorer.

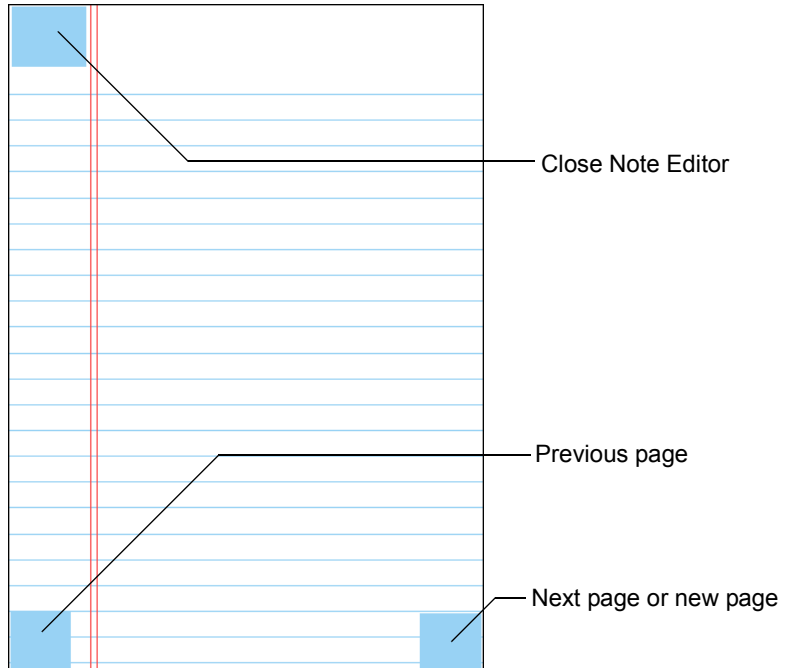

Displaying or Hiding Ruled Lines

On a desktop or Pocket PC, in Note Editor, InkNote Manager can display ruled lines that represent the preprinted lines on the paper pad. These lines appear only in Note Editor and in images you export from Note Editor; they don't appear when you print an ink note or when you copy part of an ink note.

To display or hide the lines:

1. In Explorer, open the **Setup** menu and choose **Preferences**.

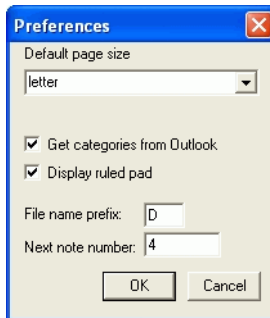

2. Select or clear **Display ruled pad**.

See Also

“Exporting an Ink Note” on page 52
“Printing an Ink Note” on page 83
“Using Cut, Copy, and Paste” on page 77

Adding to an Ink Note

To add ink to an existing ink note, open the ink note in Note Editor. Then do either of the following:

- Write on the notepad using the ink pen. This method produces the highest resolution inking.
If your writing doesn't appear in Note Editor, InkNote Manager's power-saving features have turned off the infrared port. Switch to another application and then switch back, or exit and then restart InkNote Manager. Either way, InkNote Manager reenables the infrared port.
- Select the **Write** tool and then use the stylus to draw on the handheld screen. (In the desktop application, use the mouse or other pointing device.)



See Also

- “Opening an Ink Note” on page 66
- “Adding a Page” on page 50
- “Drawing Straight Lines” on page 73
- “Adding a Highlight” on page 74
- “Setting Ink and Highlight Colors” on page 75

Drawing Straight Lines

InkNote Manager can enhance your freehand drawings by inserting perfectly straight line segments in place of ink lines that you draw with the pen, stylus, or mouse. This feature makes it easy to create professional-looking floor plans and other illustrations as you sketch.

To draw a straight line:

1. Open the **Tools** menu and choose **Straight lines**.
2. If you’re drawing with the stylus or a mouse, select the **Write** tool.
3. When you want to draw a straight line segment, “double-click” at the beginning of the line segment. That is, depress the pen point, stylus, or mouse button; raise the pen point or stylus or release the mouse button; and then depress it again on the same spot. The computer beeps to confirm that you’re about to create a straight line. (Unlike an ordinary mouse double-click, you do not release the mouse button—or raise the pen or stylus—a second time; keep it depressed.)
4. Draw. As you move the pen, stylus, or mouse, a straight line connecting the beginning of the line segment and the current pen, stylus, or mouse pointer location appears on the screen.
5. When you reach the end of the line segment, raise the pen point or stylus or release the mouse button.
6. To draw another straight line, repeat steps 3 through 5.

Straightening Existing Lines

InkNote Manager can replace existing lines on an ink note with straight lines. This makes it possible to convert your rough sketches into professional-looking floor plans or other types of illustrations. You can select multiple lines and straighten them all with a single command.

To straighten one or more freehand lines:

1. Select the lines you want to straighten.
2. Open the **Edit** menu and choose **Straighten line**.

InkNote Manager replaces each selected line with a straight line that connects the original line's starting point and ending point.

Note that InkNote Manager records the starting point and ending point of each stroke you make with the pen, stylus, or mouse. Therefore, when you draw polygons or other complex shapes, it's important to raise the pen point or stylus or release the mouse button at the end of each line segment. For example, if you draw a rectangle in one continuous motion and then subsequently select the rectangle and straighten its lines, you'll be disappointed with the result. Instead of a neat rectangle, you'll have a single dot or tiny line segment directly connecting the points where you began and ended the original stroke. (If you get such a surprise, you can revert to your original stroke by opening the **Edit** menu and choosing **Undo straighten line**.)

See Also

"Selecting Parts of an Ink Note" on page 76

"Drawing Straight Lines" on page 73

Adding a Highlight

A highlight in an ink note serves a function similar to that of a highlighter pen on paper documents. A highlight fills a rectangular area with a color of your choice. As with real felt pens, you'll get the best results with light colors—yellow, cyan, and magenta. With the other colors, ink strokes in most colors become difficult or impossible to see.

To add a highlight:

1. Select the **Highlight** tool.



2. Point at one corner of the area you want to highlight. Drag to the opposite corner.

Setting Ink and Highlight Colors

You can specify any of seven colors for ink strokes and for highlights. Even if you have a monochrome display on your handheld, InkNote Manager includes all color information when it saves the file. Therefore, when you view the ink note on your desktop PC, all colors are properly displayed.

To set colors, follow these steps:

1. Open the **Tools** menu and choose **Writing properties**.

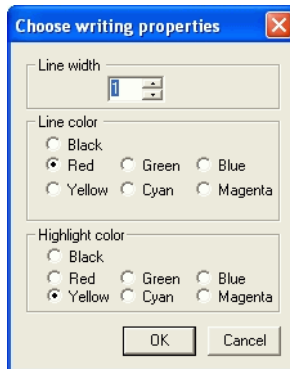

2. In **Line width**, select a width for ink strokes.
3. In **Line color**, select a color for ink strokes.
4. In **Highlight color**, select a color for highlights.

The settings you make apply to any lines and highlights that are selected when you execute the command, as well as lines and highlights you add thereafter.

Different line widths are not visible on the Palm, but will appear on the desktop.

Selecting Parts of an Ink Note

You might want to select some or all of the ink on a note. You need to do this when you want to move or delete certain parts, or if you want to copy certain parts to another page, another ink note, or a document in another application.

Ink that you select appears bold while it's selected. Selected highlights are shown as a series of diagonal lines.

To select parts of an ink note, begin by selecting the Select tool.



Then do any of the following:

- To select or deselect an individual ink stroke, click the stroke.
- To select or deselect a highlight, click an edge of the highlight.
- To select all strokes and highlights in an area, drag a rectangle.
 - Dragging a rectangle from left to right selects all strokes and highlights that fall completely within the rectangle.
 - Dragging a rectangle from right to left selects all strokes and highlights that are completely or partially in the rectangle.

Items that you select remain selected until you deselect them. You can continue to select multiple items.

To deselect a selected stroke, click it. To deselect a selected highlight, click one of its edges. To deselect all selected items, click anywhere except on a stroke.

See Also

“Using Cut, Copy, and Paste” on page 77

“Grouping and Ungrouping Parts of an Ink Note” on page 78

Using Cut, Copy, and Paste

Once you have selected ink strokes, highlights, or both, you can cut or copy the selected graphics to the Windows Clipboard. To do so:

- Open the **Edit** menu and choose **Cut** or **Copy**.
- Click the **Cut** or **Copy** button on the toolbar (desktop version only).



- Right-click anywhere in the image area and choose **Cut** or **Copy** from the shortcut menu (desktop version only).

Once the selected graphics are on the Clipboard, you can paste them to any page of any ink note. To paste into an ink note, follow these steps:

1. Display the ink note page where you want the graphics to appear.
2. Open the **Edit** menu and choose **Paste**. With the desktop application, you can use either of these alternative techniques:
 - Click the **Paste** button on the toolbar (desktop version only).



- Right-click anywhere in the image area and choose **Paste** (desktop version only).
3. Drag the pasted graphics (which are still selected) to the location you want.

On a Pocket PC, you can also paste Clipboard contents into other applications that accept stylus input, such as Pocket Word, Contacts (Notes tab only), and so on. To paste into one of these applications:

1. Select the parts of the ink note that you want to use in another application. Cut or copy the information to the Clipboard, as described above.
2. Switch to the other application. Be sure the application is in a mode that accepts stylus input. (If you're unsure, try drawing on the screen with the stylus.)
3. Open the Edit menu and choose Paste.

Note that you can paste an ink note item from the Clipboard only one time. (Most types of copied information remain on the Clipboard until they're replaced with something else.) If you want to paste an image more than one time, you'll need to switch back to InkNote Manager and recopy it before each paste operation.

See Also

"Selecting Parts of an Ink Note" on page 76

Moving Part of an Ink Note

To move ink strokes, highlights, or both:

1. Select the parts of the note you want to move.
2. Drag to the new location.

See Also

"Selecting Parts of an Ink Note" on page 76

Grouping and Ungrouping Parts of an Ink Note

When you write or draw in InkNote Manager, each ink stroke and highlight is a separate object that can be independently selected, copied, moved, and so on. You might want to treat a number of strokes as one object. For example, a signature or a map is easier to deal with as a single object. *Grouping* combines multiple ink strokes and highlights into a single object that you can then select with a single click on any of its component strokes.

To group parts of an ink note:

1. Select the parts of the note you want to group.
2. Open the **Edit** menu and choose **Group Strokes** or **Group**.

To ungroup strokes and highlights that you have previously grouped:

1. Click any of the grouped strokes or the edge of a grouped highlight to select the group.

2. Open the **Edit** menu and choose **Ungroup Strokes** or **Ungroup**.

See Also

“Selecting Parts of an Ink Note” on page 76

Undoing an Edit

With the exception of adding or deleting a page, you can undo any change you make in Note Editor. Simply open the **Edit** menu and choose **Undo**. On a Pocket PC or desktop you can choose the command repeatedly to undo multiple actions. On the Palm there is only one level of undo.

If you undo an edit that you didn't mean to, open the **Edit** menu and choose **Redo**. You must do so after you choose Undo and before you make any additional edits.

In the desktop application, you can use the **Undo** and **Redo** toolbar buttons as an alternative to the Edit-menu commands.



Using Handwriting Recognition

On a Pocket PC you can use the operating system's handwriting recognition capability to turn your ink notes into text.

Follow these steps to turn ink notes into text:

1. On the Pocket PC, select the text you want to convert.
2. Open the **Edit** menu and choose **Copy**.
3. Open the **Start** menu and choose **Notes**.
4. Tap **New**.
5. Open the **Edit** menu and choose **Paste**.

6. Open the **Tools** menu and choose **Recognize**.

See Also

“Selecting Parts of an Ink Note” on page 76

Communicating Notes

InkNote Manager makes it easy to send ink notes to other computers and devices. This section explains how to:

- E-mail an ink note
- Beam an ink note
- Print an ink note

Sending Ink Notes

You can send an ink note to other users as an attachment to an e-mail message. To send an ink note to someone who has InkNote Manager, you can retain its native file format; for others, you can use one of the standard graphics formats.

If you have another computer with an infrared port, such as a laptop computer or another handheld, you can beam an ink note to that computer. Both computers must have InkNote Manager installed.

And, of course, you can create printed hard copies of your ink notes. InkNote Manager lets you print multiple note pages on a single printed page, offers print preview, various zoom levels, and other unique printing capabilities.

E-mailing an Ink Note

To e-mail an ink note:

1. Open the note in Note Editor.
2. Open the **File** menu and choose **Send via Email** or **Email Note**.
3. Select a file type for the attachment:
 - *.INK* or *Native*. This is the native file format for InkNote Manager. If you're sending to someone who has InkNote Manager, use this format. This is the only format that supports multipage notes in a single file; the other formats create a separate file for each page. Also, this format allows the recipient to edit the ink notes with InkNote Manager.
 - *.BMP*. Bitmap graphics files (.bmp file name extension) can be viewed with Microsoft Paint and most graphics-viewing programs. The files are quite large.
 - *.JPG*. Files in Joint Photographic Experts Group format (.jpg file name extension) can be viewed by anyone with a Web browser. (They can be viewed in most graphics-viewing programs as well.) This format provides fairly small file sizes and excellent compatibility.
 - *.PNG*. Portable Network Graphics files (.png file name extension) can be viewed with most modern Web browsers and graphics-viewing programs. Files in this format are small and better quality than .JPG; some recipients won't have the appropriate software to view them, however.
4. On a desktop or Pocket PC, specify the **Resolution** in dots per inch. (The default resolution is 72.) Higher numbers produce sharper images, but larger files.
5. Click **OK**.

6. Fill in the standard e-mail header address fields: **to**, **cc**, and **bcc**. Tap **Contacts** or **Lookup** to select a name from your Contacts database. Separate multiple addresses with a semicolon (;).
7. In the **subject** and **body** boxes, type a message to go along with your attached file.
8. Click **OK**.

Unless your handheld has email capability, the message is now queued to go to the desktop computer the next time you synchronize. The e-mail program in your desktop computer actually sends the message.

Beaming an Ink Note

To beam an ink note from one computer to another, both computers must have infrared ports and have InkNote Manager installed. You must remove your handheld from the SmartPad portfolio to beam an ink note.

To send an ink note, do either of the following:

- Display the ink note in Note Editor. Open the **File** or **Note** menu and choose **Send via Infrared** or **Beam Note**.
- On a Pocket PC, in Explorer, tap and hold the ink note you want to send. Choose **Send via Infrared** from the shortcut menu.

To receive a beamed ink note, on the other computer open the **File** menu and choose **Receive via Infrared**.

Align the infrared ports and follow the on-screen instructions.

Printing an Ink Note

In the desktop application, you can print an ink note displayed in Note Editor by opening the File menu and choosing Print. Nothing unusual there, but when the dialog box appears, you'll see some options that you might not have encountered in other applications, as shown below.

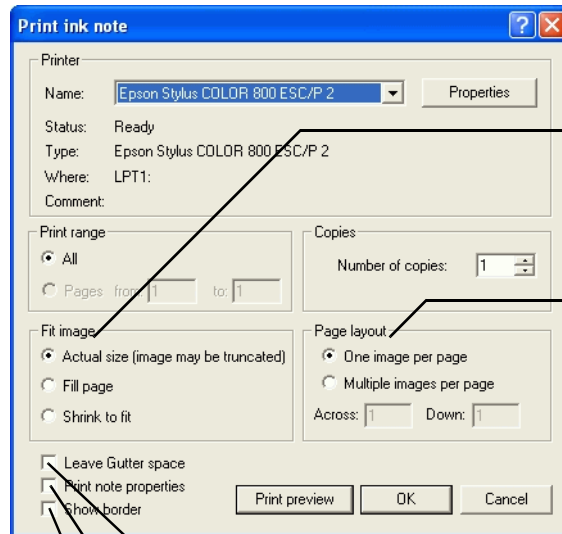

These options scale the image to fit the page.

These options allow you to print multiple ink note pages on each printed page.

Selecting this check box moves the printing to the right, leaving a binding margin on the left edge of the page.

Selecting this check box causes an ink note's file name, creation and change dates, categories, and key words to print at the bottom of each page.

Selecting this check box prints a border around the ink notes.

Archiving and Backing Up

The desktop version of InkNote Manager provides a way to automatically save ink notes to an archive folder. This section explains how to:

- Set archive options
- View archived ink notes
- Restore archived ink notes
- Archive intermediate versions

Why Archive?

InkNote Manager stores ink notes on your handheld and your desktop computer. They're easy to find and use.

But at some point you'll need to delete some older notes. For example, if your handheld runs low on memory, you might choose to delete some of its stored ink notes. The next time you connect with ActiveSync, it automatically deletes the same ink notes from your desktop computer. Fortunately,

InkNote Manager's archive feature automatically creates a backup on your desktop computer.

This feature allows you to keep the collection of ink notes stored on your handheld lean and small, while still having full access to all your previous ink notes. Deleting unnecessary ink notes from the handheld provides other, perhaps unexpected, benefits as well:

- Frees up memory for other applications and documents
- Improves performance because Explorer spends less time reading documents and creating thumbnail images
- Reduces power consumption, thereby prolonging battery life between charges

A copy of each ink note that has changed is saved each time you exit InkNote Manager. To distinguish different versions of the ink notes, InkNote Manager appends a version number—in the form “(v1),” “(v2),” and so on—to the file name in the archive folder.

The way the archive feature works is quite simple: when enabled, it retains a copy of each version of each ink note in a second folder on the desktop computer. This folder is not synchronized with the handheld by ActiveSync. You can view the contents of the archive folder in Explorer in exactly the same way that you view the contents of primary storage location.

Setting Archive Options

To enable or disable automatic archiving:

1. Using Explorer in the desktop version of InkNote Manager, open the **Setup** menu and choose **Archive options**.

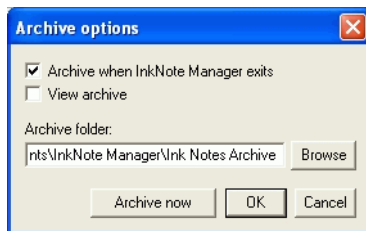

2. Select or clear **Archive when InkNote manager exits**.
3. To specify the location of the archive folder, type the path in the **Archive folder** box.

Viewing Archived Ink Notes

In Explorer, you can display either the ink notes in the primary storage location (that is, the folder that ActiveSync synchronizes with your handheld) or the ink notes in the archive folder.

To view the archived ink notes:

1. In Explorer, open the **Setup** menu and choose **Archive options**.
2. Select **View archive**.
3. Click **OK**.

The title bar in Explorer reads “InkNote Manager (Archive folder)” when Explorer displays archived ink notes. Each archived ink note is given a unique name. The names are created by appending “(v1),” “(v2),” and so on to the name of the original ink note file.

Restoring Archived Ink Notes

If you need to use an archived ink note, you must save it in a different location because archived ink notes are marked read only.

To restore an archived ink note:

1. In Explorer, open the archived ink note that you want to restore.
2. In Note Editor, open the **File** menu and choose **Save As**.
3. Enter a name for the ink note.
4. Click **Save**.

This procedure saves the restored ink note in the primary storage location (that is, the folder that ActiveSync synchronizes with your handheld). It will appear in Explorer on your Pocket PC the next time you synchronize.

Archiving Intermediate Versions

Ink Note Manager normally archives changed ink notes when you exit the program. You can also save changed ink notes at other times.

To archive changed ink notes:

1. In Explorer, open the **Setup** menu and choose **Archive options**.
2. Click **Archive now**.
3. Click **OK**.

Advanced Tasks

This section explains additional configuration and maintenance tasks:

- Configure InkNote Manager
- Maintain InkLink
- Maintain SmartPad
- Upgrade or uninstall InkNote Manager

Other Configuration Options

- Set default file name for new ink notes
- Use the SmartPad tablet keyboard
- Configure power-saving options
- Use multiple handhelds
- Use InkNote Manager on a desktop computer only

Setting the Default File Name

When you create an ink note, InkNote Manager uses a default file name when you initially save an ink note. (On a desktop or Pocket PC you can provide your own more descriptive name when you save a file.) By default, InkNote Manager uses a letter (*N* for notes you create on your handheld; *D* for notes you create on your desktop computer) followed by a sequential number.

To change the default file name:

1. In Explorer, open the **Setup** menu and choose **Preferences**.

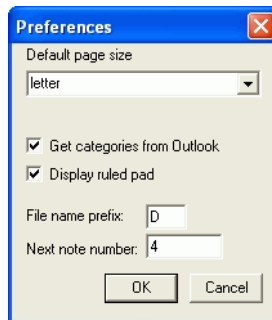

2. Specify the text you want to use at the beginning of each file name in **File name prefix**. (On a desktop or Pocket PC you can also set the number of the next note, but this counter increments automatically.)

Using the SmartPad Tablet as a Keyboard

The SmartPad 2 portfolio has a keyboard printed on the tablet underneath the paper pad. On a Pocket PC, you can use this keyboard for entering text into any program.

SmartPad owners can add this capability using an accessory keyboard label. The label and installation instructions are included in the SmartPad package.

To configure the tablet keyboard:

1. In InkNote Manager's Explorer, open the **Setup** menu and choose **Tablet properties**.

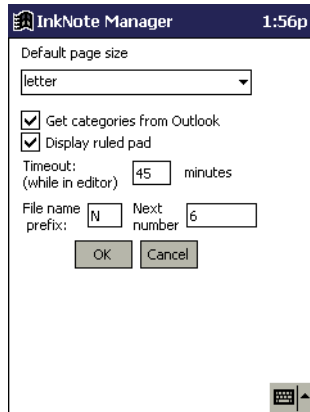

2. Clear **Enable tablet only in InkNoteMgr** and select **Use tablet as kybd in other apps**.

To use the keyboard tablet:

1. Start InkNote Manager. (Even if you plan to enter text in a different program, InkNote Manager must be running, as it provides the tablet driver. If you exit InkNote Manager, the pen becomes inactive.)
2. Switch to any application.
3. Lift the paper (or remove the pad) and tap the keys using the writing end of the pen (not the stylus end).
 - Tap **Int'l** to enter the blue characters in the upper right corner of each key.
 - Tap **Alpha** to switch back to entering the standard black characters.

Power-Saving Features

Using a handheld with InkLink or SmartPad uses more power than using a handheld alone because they communicate through an infrared link. The SmartPad tablet and SmartPad pen are self powered. The InkLink pen and IrDA transceiver are self powered. InkNote Manager includes several features to minimize the power drain on all three devices.

When you use InkNote Manager's Explorer, the operating system controls the handheld's power-management features. To adjust these settings:

1. Open the **Start** menu and tap **Settings**.
2. Tap the **System** tab and tap the **Power** icon.
3. Specify the time after which the handheld turns off if it's not used.

Note that when the handheld turns off, the communications link with the InkLink data clip or SmartPad portfolio is broken. To reestablish communications, tap the **File** or **Setup** menu in InkNote Manager. Alternatively, exit InkNote Manager and restart the program. InkNote Manager always establishes a communications link when the program starts.

When you use InkNote Manager's Note Editor, a different timer controls when the handheld turns off. This prevents the handheld from shutting off too frequently while you're writing notes.

To set this timer on a Pocket PC:

1. In Explorer, open the **Setup** menu and choose **Preferences**.

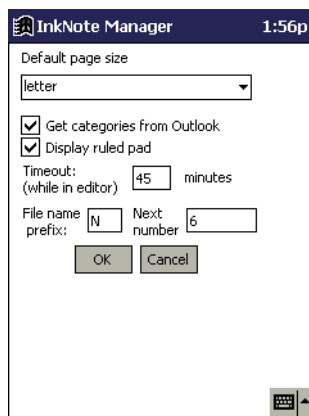

2. In the **Timeout (while in editor)** box, specify the time after which the handheld turns off if it's not used.

To set this timer on a Palm:

1. Tap the **Applications** icon.

2. Tap the **Preferences** icon.
3. Tap the pick list in the upper-right corner and select **General**.

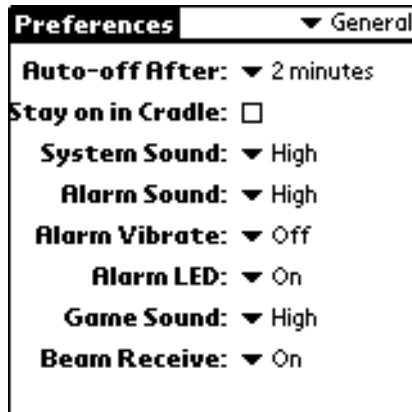

4. In the **Auto-Off After** pick list, choose a time.

As long as you write on the tablet before the time you specify here elapses, the handheld screen remains on. (In addition, InkNote Manager prevents the InkLink data clip or SmartPad portfolio from powering down while Note Editor is open and the handheld is turned on.) If you pause for a longer time, the handheld turns off.

If you want to start writing again after the screen has blanked, you must wake up the InkLink or SmartPad. You do that by pressing the pen to the paper and holding it until the screen turns on—one to two seconds.

If no pen input is received for a longer period of time, InkNote Manager closes the port and lets the handheld shut down. To wake the handheld from this state you must press the power button. (On a Pocket PC, press the power button two times.)

On a Pocket PC, you can conserve power and extend battery life between charges in other ways too:

- After syncing with your desktop computer, delete ink notes that you're no longer currently using. (The desktop version of InkNote Manager saves an archive version of deleted ink notes.) This speeds up the pro-

gram and, because it reduces the load on the processor, actually improves battery performance.

- Exit InkNote Manager when you're through using it.

You can make other settings in InkNote Manager to conserve battery life on your Pocket PC:

1. In Explorer, open the **Setup** menu and choose **Tablet properties**.

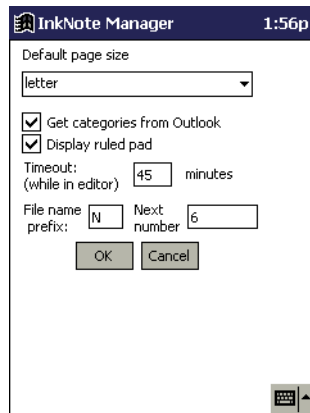

2. Select or clear any of the check boxes:

- Clear **Tablet active** to disable the device altogether. Doing so turns off the port and the tablet for maximum power saving; this is effectively the same as closing InkNote Manager. You might want to do this when you want to write on the tablet without capturing your key-strokes.
- Select **Enable tablet only in InkNoteMgr** to turn off the port when you switch to any other program. If this check box is not selected, the port remains open when you switch to other programs, thereby consuming power. Unless you use the tablet keyboard in other programs, you should clear this check box.

- Select **Use tablet as kybd in other apps** only if you want to use the SmartPad keyboard.

See Also

“Using the SmartPad Tablet as a Keyboard” on page 90

Using InkNote Manager with Multiple handheld Devices

You can use InkNote Manager on your desktop to partner with several handhelds, including both Palm and Pocket PC devices.

Microsoft’s ActiveSync allows you to partner more than one Pocket PC with a desktop computer—and InkNote Manager supports that feature as well. ActiveSync assigns a name to each partnered handheld device. It then uses that name to create a uniquely named folder in your desktop computer’s My Documents folder. That folder contains the files to be synchronized with a particular handheld. (For example, you might have a folder named My Documents\Color_PocketPC My Documents, which syncs with the My Documents folder on the device named Color_PocketPC. Other folders would sync with the My Documents folders of other partnered handhelds.)

Ink notes from a Pocket PC are stored by default in the \My Documents\Seiko Ink Notes folder on a handheld; this folder syncs to the My Documents\Pocket_PC My Documents\Seiko Ink Notes folder on your desktop computer, where *Pocket_PC* is the device name of your handheld. (Depending on which version of Windows you use, your My Documents folder might not be in the root directory. But you can always find it by opening My Computer; My Documents appears as a subfolder of Desktop, the item at the top of the hierarchy.)

To determine (or change) the name of your Pocket PC, follow these steps:

1. On the Pocket PC, open the **Start** menu and choose **Settings**.
2. Tap the **System** tab and then tap **About**.
3. Tap the **Device ID** tab.

On a Palm, all of your ink notes are contained inside the InkNote Manager application. When you sync with your desktop, the ink notes are stored in the \Program Files\Palm*name*\Seiko Ink Notes folder.

To determine the name of your Palm, follow these steps:

1. Put your Palm handheld in the cradle or connect the cable.
2. Press the HotSync button on the cradle or cable.

When HotSync is finished, the device name appears in the upper-right corner of the screen.

Choosing a Sync Partner

Explorer in the desktop version of InkNote Manager displays the notes from only a single handheld at any time. To select the handheld that interacts with InkNote Manager:

1. Open the **Setup** menu and choose **Select Sync partner**.
2. In the dialog box that appears, select the device you want to sync with.

Specifying a Storage Location for Your Ink Notes

If you use InkNote Manager only on your desktop computer and you do not synchronize files with a handheld using ActiveSync, you must specify a storage location for your ink notes before you can create or view ink notes. To specify a location:

1. On your desktop computer, open the **Start** menu and choose **Programs, InkNote Manager, Run InkNote Manager**.
2. In InkNote Manager, open the **Setup** menu and choose **Define note storage location**.

Enter the path to the folder you want to use (or click **Browse** to navigate to the folder). Most users prefer to use their My Documents folder or a sub-

folder of My Documents that they create, such as My Documents\Seiko Ink Notes.

See Also

“Selecting a handheld as a Partner” on page 38

InkLink Maintenance Procedures

- Replace the InkLink pen ink cartridge
- Replace InkLink pen batteries
- Replace InkLink IrDA transceiver batteries

Replacing the InkLink Pen Ink Cartridge

The InkLink pen uses a Staedtler 930 series ball point pen refill that is widely available at office supply stores. They are available in black, blue, and red.

To replace an ink cartridge:

1. Fit the tip of the InkLink pen into the center of the top of the cap.

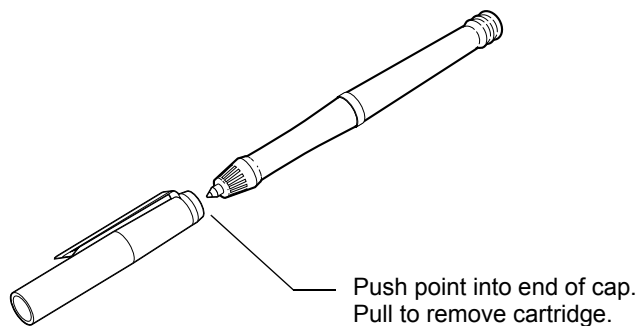

2. Pull the pen away from the cap holder to extract the cartridge.

3. Place the fresh ink cartridge into the end of the InkLink pen. Press the tip of the pen onto a hard surface until the cartridge won't go in any further.

See Also

“Purchasing Supplies” on page 118

Replacing the InkLink Pen Batteries

The InkLink pen is powered by three SR41 button batteries. With regular use of your InkLink, these batteries should power the InkLink pen for several months.

If you find that your handwritten data no longer appears in InkNote Manager, it's probably time to replace the batteries in the InkLink pen. You can find replacement batteries at most stores that sell cameras or electronic devices.

To replace the batteries:

1. Unscrew the battery cap from the pen.
2. Remove the three batteries. You might have to shake the pen to remove the batteries.

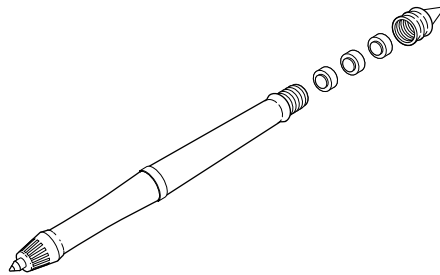

3. Insert fresh SR41 batteries. The positive (+) end of the batteries should all be facing up.
4. Screw the battery cap back on the pen.

Used batteries are hazardous waste and should be disposed of appropriately.

Replacing the InkLink IrDA Transceiver Battery

The InkLink data clip is powered by a single AAA battery in the IrDA transceiver. (When connected to a desktop, it is powered via the cable.). To install the battery:

1. Remove the clip by sliding it away from the battery case.
2. Slide the battery cover away from the cable to remove the cover.

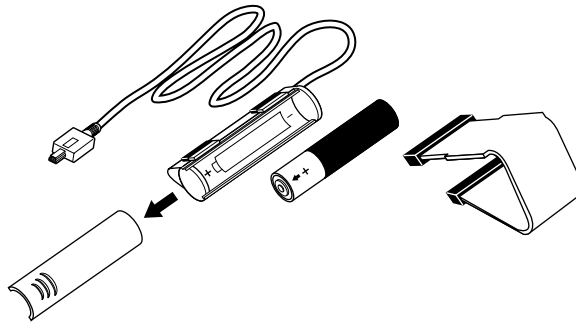

3. Insert the battery into the battery compartment. Be sure the positive (+) end of the battery points away from the cable.
4. Replace the battery cover and slide it into place.
5. Replace the clip.

Used batteries are hazardous waste and should be disposed of appropriately.

SmartPad Maintenance Procedures

- Replace the SmartPad pen ink cartridge
- Replace SmartPad pen battery
- Replace SmartPad portfolio batteries
- Attaching Your handheld To SmartPad

Replacing the SmartPad Pen Ink Cartridge

Spare ink cartridges for the SmartPad pen are included with SmartPad. The spare ink cartridges are located in the storage pocket of the SmartPad portfolio. The spare ink cartridges are stored in a cartridge holder, which also incorporates a tool that removes expended ink cartridges.

To replace an ink cartridge:

1. Fit the tip of the SmartPad pen into notch of the removal tool.

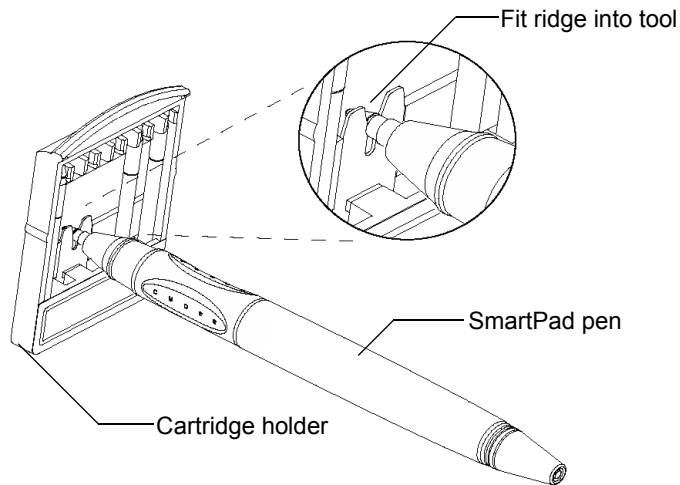

2. Pull the pen away from the cartridge holder to extract the cartridge.

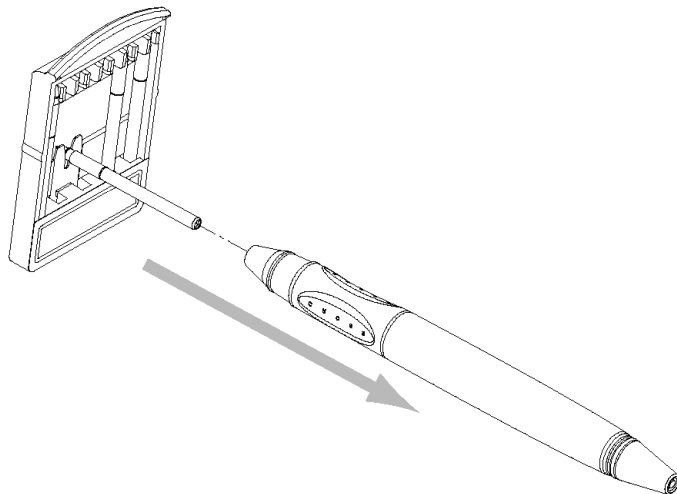

3. Remove a fresh ink cartridge from the cartridge holder.
4. Place the fresh ink cartridge into the end of the SmartPad pen. Press the tip of the pen onto a hard surface until the cartridge won't go in any further.

See Also

“Purchasing Supplies” on page 118

Replacing the SmartPad Pen Battery

The SmartPad pen is powered by a standard AAAA battery. With regular use of your SmartPad, this battery should power the SmartPad pen for several months.

If you find that your handwritten data no longer appears in InkNote Manager, it's probably time to replace the battery in the SmartPad pen. You can find a replacement battery at most stores that sell cameras or electronic devices.

To replace the battery:

1. Using two hands, grasp the pen by the rubberized grip and by the pen's long barrel.

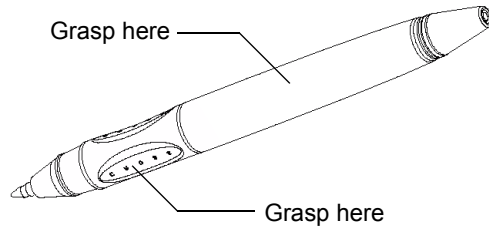

2. Twist the pen to unscrew the two sections.
3. Separate the two sections and remove the battery.

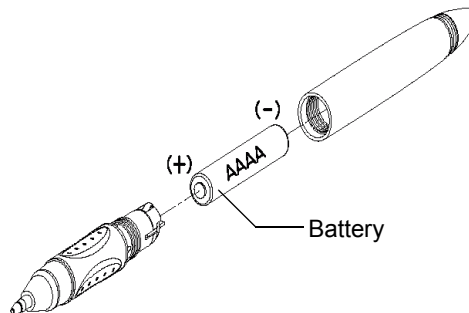

4. Insert a fresh AAAA alkaline battery. The positive (+) end of the battery should be closest to the pen's writing tip.
5. Reassemble the two sections of the pen together.

Replacing SmartPad Portfolio Batteries

The SmartPad portfolio is powered by two AAA batteries. To install the batteries in the SmartPad portfolio:

1. Press down on the top edge of the battery cover and then slide the cover toward the bottom of the portfolio to remove the cover.

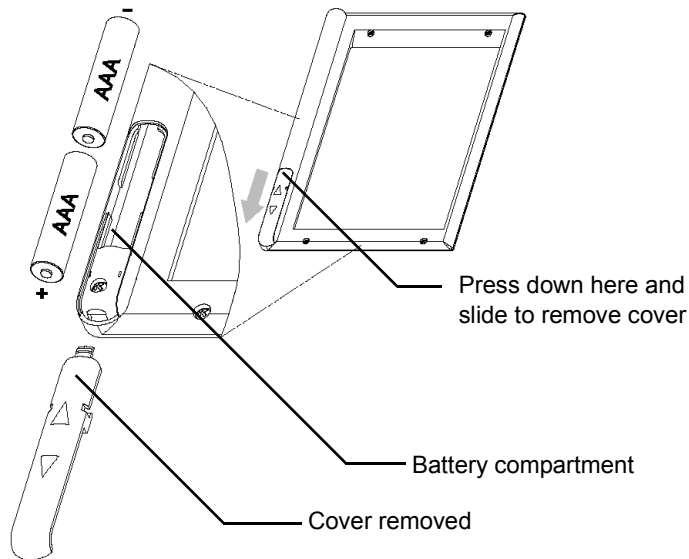

2. Insert the batteries into the battery compartment. Be sure the positive (+) end of both batteries points toward the bottom of the portfolio.
3. Replace the battery cover and slide it into place.

Used batteries are hazardous waste and should be disposed of appropriately.

See Also

“Replacing the SmartPad Pen Battery” on page 101

Repositioning the SmartPad 2 Infrared Transceiver

As shipped, SmartPad 2 is set to work with handhelds that have the infrared port located on the top edge of the handheld. (The original SmartPad works only with such handhelds.) On some handhelds, the infrared port is located on the left side. To use SmartPad 2 with handhelds that have an infrared port on the left side, you must reposition SmartPad’s infrared transceiver. To reposition the transceiver:

1. Pull to remove the round cap on the transceiver.

2. With the round cap removed, pull straight up to remove the arm of the infrared transceiver from the snap retainers of the SmartPad portfolio. Be aware that a wire connects this arm to the SmartPad portfolio—take care not to pull on the wire as you remove the arm of the infrared transceiver.

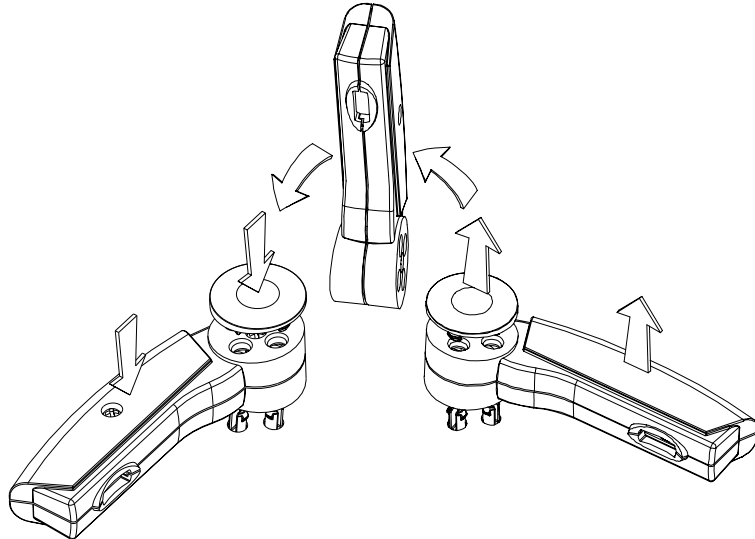

3. Turn the infrared transceiver arm over, and press it down firmly until it “snaps” into place in the new position in the SmartPad portfolio.
4. You may need to gently feed the wire of the infrared transceiver arm into the cover of the SmartPad portfolio. Be careful! You want the infrared arm to be seated firmly and securely into the SmartPad portfolio.
5. Replace the round cap to secure the arm of the infrared transceiver.

Attaching Your handheld To SmartPad

Your handheld must be placed in the designated area of the SmartPad portfolio so the infrared ports of the two devices can communicate properly. Two self-adhesive strips of hook-and-loop material keep the handheld securely in place.

The hook-and-loop material provides an extremely aggressive bond. That’s terrific if you plan to leave your handheld in the SmartPad portfolio nearly all the time. But if you expect to frequently remove and replace the hand-

held from the portfolio, we suggest you use only half of the self-adhesive loop material, as follows:

1. Without separating the backing strips, remove the two loop strips from the portfolio's hook strips to which they're attached.
2. Cut one of the strips in half lengthwise. Save the other strip for future use.
3. Replace the two half strips on the portfolio's matching hook material.
4. Continue with the following procedure.

To attach the handheld:

1. Remove the backing from the self-adhesive strips in the SmartPad portfolio.
2. Place the handheld on the strips, centering it on the pad area to which the hook-and-loop strips are attached.

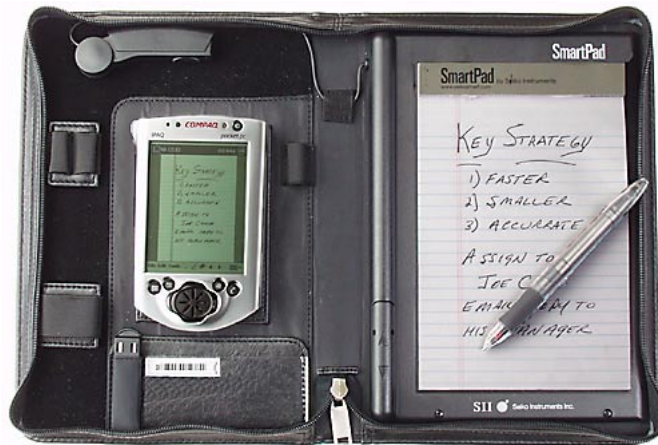

3. Press firmly to adhere the strip to your handheld.
4. Remove your handheld from the SmartPad, turn the handheld over, and press the loop strips so that they're securely, permanently adhered.

InkNote Manager Maintenance

- Uninstall InkNote Manager from a desktop computer
- Uninstall InkNote Manager from a Pocket PC
- Uninstall InkNote Manager from a Palm
- Upgrade to a new version of InkNote Manager

Uninstalling InkNote Manager from a Desktop Computer

To remove InkNote Manager from your desktop computer:

1. Open Control Panel and double-click **Add/Remove Programs**.
2. Select **InkNote Manager** and click **Add/Remove** or **Change/Remove**. (The button text depends on the version of Windows you use.)
3. In the dialog box that appears, select **Remove** and then click **Next**.

Uninstalling InkNote Manager from a Pocket PC

To remove InkNote Manager from your Pocket PC, use the following procedure on your desktop computer:

1. Be sure your Pocket PC is connected to your desktop computer.
2. On the desktop computer, choose **Start, Programs, Microsoft ActiveSync** to open ActiveSync.
3. In ActiveSync, open the **Tools** menu and choose **Add/Remove Programs**.
4. Clear the check box by **Seiko InkNote Manager** and then click **OK**.

If you want to remove the files for the handheld version of InkNote Manager from your desktop computer and your handheld, highlight **Seiko InkNote Manager** and then click **Remove**. This removes the handheld files from the desktop computer (thereby preventing easy reinstallation) but it does not uninstall the desktop version of InkNote Manager. To reinstall to the handheld, you'll need to use the original CD-ROM.

Alternatively, you can remove InkNote Manager from your Pocket PC by using the following procedure:

1. Open the **Start** menu and tap **Settings**.
2. Tap the **System** tab.
3. Tap **Remove Programs**.
4. Select **Seiko InkNote Manager** and tap **Remove**.

Uninstalling InkNote Manager from a Palm device

To remove InkNote Manager from your Palm:

1. Tap the **Applications** icon.
2. On the **App** menu, select **Delete**.
3. Tap **InkNote Manager**.
4. Tap **Delete**.

Upgrading InkNote Manager

If a new version of InkNote Manager becomes available, you might need to demonstrate your eligibility to obtain and install the new version by providing your serial number.

To find your serial number, in the desktop version of InkNote Manager, open the **Help** menu and choose **About**.

Then, before you install the new version of InkNote Manager, you should uninstall your current version. All your existing ink notes, archives, and settings will be preserved.

See Also

“Uninstalling InkNote Manager from a Desktop Computer” on page 106

“Uninstalling InkNote Manager from a Pocket PC” on page 106

“Uninstalling InkNote Manager from a Palm device” on page 107

Troubleshooting

This section explains how to diagnose and solve problems that might occur. Each problem includes a series of steps to try, in order, until the problem is resolved.

- Test the components
- InkLink ink strokes do not appear on the screen
- SmartPad ink strokes do not appear on the screen
- InkLink ink notes do not match paper notes
- InkLink does not work reliably
- Screen blanks while writing
- SmartPad Pen gestures don't work
- Ruled lines on screen don't match notepad paper
- Computer doesn't beep when drawing straight lines
- Handheld Does Not Appear in Sync Partner List
- Error: Unable to open the port
- Error: No port found

- Short battery life

Testing the handheld and InkLink or SmartPad

InkNote Manager provides a diagnostic test that you can use to confirm proper setup and operation. To test the devices:

1. In Explorer, open the **Setup** menu and choose **Test Tablet**.
2. Write on the tablet.

The display should show the location (**X** and **Y**) of the pen and whether it's writing (**Status**). If these values do not change as you move the pen, review the following sections.

See Also

“InkLink Ink Strokes Do Not Appear on the screen” on page 110

“SmartPad Ink Strokes Do Not Appear on the screen” on page 111

“Error: Unable to open the port’ Message” on page 115

“Error: No port found’ Message” on page 115

InkLink Ink Strokes Do Not Appear on the screen

Work through the following list until the solution is found.

1. Be sure the handheld is turned on and that InkNote Manager is running.
2. Check that there is a blinking red light inside the left receiver on the data clip. If not, replace the battery in the IrDA transceiver.
3. Check that the blink rate increases when the pen is depressed on the paper. If not, replace the pen batteries.
4. Make sure the IrDA transceiver is aligned with the handheld's infrared port. The alignment is not as critical if the IrDA transceiver is not tight against the infrared port on the handheld.
5. Press the pen down on the paper for 5 seconds.
6. In InkNote Manager, tap a menu and then tap elsewhere to close the menu.

-
7. In InkNote Manager Explorer, open the **Setup** menu and choose **Select pen hardware**. Be sure that **InkLink** is selected.
 8. In InkNote Manager Explorer, open the **Setup** menu and choose **Tablet properties**. Be sure that **Tablet active** is selected.
 9. In InkNote Manager Explorer, on the **Setup** menu, choose **Test Tablet**. Use the pen to write on the pad and see if information appears on the screen.
 10. Switch to another program and then switch back to InkNote Manager. (This causes it to reopen the port.)
 11. Reset the handheld.

See Also

“Power-Saving Features” on page 91

“Replacing the InkLink IrDA Transceiver Battery” on page 99

“Replacing the InkLink Pen Batteries” on page 98

SmartPad Ink Strokes Do Not Appear on the screen

Work through the following list until the solution is found.

1. Be sure the handheld is turned on and that InkNote Manager is running.
2. Make sure the transceiver is aligned with the handheld's infrared port.
3. Press the pen down on the paper for 5 seconds.
4. In InkNote Manager, tap a menu and then tap elsewhere to close the menu.
5. In InkNote Manager Explorer, open the **Setup** menu and choose **Select pen hardware**. Be sure that **SmartPad** is selected.
6. In InkNote Manager Explorer, open the **Setup** menu and choose **Tablet properties**. Be sure that **Tablet active** is selected.
7. Switch to another program and then switch back to InkNote Manager. (This causes it to reopen the port.)

8. Reset the handheld.

See Also

“Power-Saving Features” on page 91

“Replacing SmartPad Portfolio Batteries” on page 102

“Replacing the SmartPad Pen Battery” on page 101

InkLink ink notes do not match paper notes

There are several reasons why your ink notes might not match your paper notes. For best results:

- Keep your pen at a constant angle while you write. Since the InkLink pen’s transmitter is not right at the tip, changing the pen angle changes its relative distance from the data clip.
- Clip the data clip on the whole pad. While you can use the data clip on a single sheet of paper, it clamps more securely on multiple sheets. If the data clip slips, and changes its position on the page, it will affect your results.
- Write with even pressure on the pen. You do not have to press hard, but with too light a pressure, the pen stops transmitting, causing skips in your ink notes.
- Leave a half inch margin next to the data clip. If you are using the last few sheets of a tablet with a binding, where the data clip is well above the sheet you are writing on, you might need a larger margin.
- Keep the paper flat. A slight bend in the pad, or pushing the paper up slightly changes the distance from the pen to the data clip, and will affect your results.

InkLink does not work reliably

The InkLink Handwriting System works best in environments in which you are comfortable. The following conditions might affect performance.

- Temperatures below 5° C or above 35° C.
- Direct sunlight.

-
- Humidity above 80%, or condensing conditions.

In an office, interference from other infrared devices, such as mice or keyboards can affect performance.

Screen Blanks While Writing

Hewlett-Packard Jornada devices running Pocket PC 2002 have a power-saving feature that blanks the screen while continuing to accept input from devices such as the InkLink and SmartPad. Although the screen is blank, the device continues to send data and InkNote Manager continues to capture your strokes.

To turn the display back on, simply press the power button.

To disable this feature, follow these steps:

1. Open the **Start** menu and tap **Settings**.
2. Tap the **System** tab.
3. Tap **HP Settings**.
4. Under Power Preferences, clear the check box labeled “**Turn off the display when system cannot auto-suspend...**”

SmartPad Pen Gestures Don't Work

You can use certain pen gestures to navigate between pages and to close Note Editor: you press and hold the pen tip down in a designated area of the paper notepad in the SmartPad portfolio. If gestures don't work, confirm the following:

1. Use the writing end of the SmartPad pen.
2. Press and hold the pen tip in the designated area for at least one second.
3. The designated areas are approximately 5/8 inches (15 mm) square, and are located in the upper left corner, lower left corner, and lower right corner of the notepad.

4. In Explorer, open the **Setup** menu and choose **Preferences**. Be sure the setting in the **Default note size** box matches the size of notepad used in your SmartPad.

See Also

“Using Pen Gestures on SmartPad” on page 70

Ruled Lines on Screen Don’t Match Notepad Paper

Because of variations in printing and binding, the printed lines on the paper notepad won’t always exactly match the representation in Note Editor. If they’re not close, however, check the following:

- On a desktop or Pocket PC, in Explorer, open the **Setup** menu and choose **Preferences**.
 - Be sure the **Display ruled pad** check box is selected.
 - Be sure the setting in the **Default note size** box matches the size of notepad you are using.

See Also

“Displaying or Hiding Ruled Lines” on page 71

Computer Doesn’t Beep When Drawing Straight Lines

When you begin drawing a straight line segment, the computer should beep to signal that it’s ready to receive your input. If it does not beep, check the following:

1. Be sure that sounds are enabled.
 - On a Pocket PC, open the **Start** menu and choose **Settings**. On the **Personal** tab, tap **Sounds & Reminders**. On the **Volume** tab, be sure the **Events** check box is selected.
 - On a Palm, tap the **Applications** icon, and then tap the **Preferences** icon. Choose **General** in the pick list and be sure **System Sound** is not off.

-
2. In Note Editor, open the **Setup** menu and be sure a check mark appears next to **Straight lines**.
 3. Be sure you're depressing the pen point, raising the pen point, and then depressing it again in the same place. Do not raise the pen point a second time before you draw the line.
 4. Try performing this "double-click" action faster or slower until you find the speed that works.

Handheld Does Not Appear in Sync Partner List

If you have multiple handhelds that you sync with your desktop, they might not all appear in the Choose Partner Device list.

Install all the versions of InkNote Manager that you need at the same time. Then all your handheld devices will appear in the list.

'Error: Unable to open the port' Message

1. Tap **OK** to close the message.
2. If you have a Pocket PC 2002 model, do the following:
 - Open the **Start** menu and tap **Settings**.
 - Tap the **Connections** tab.
 - Tap the **Beam** icon.
 - Clear the **Receive all incoming beams and select discoverable mode** check box.
3. Switch to another program and then switch back to InkNote Manager.
4. Exit and restart InkNote Manager.
5. Reset your handheld.

'Error: No port found' Message

1. Tap **OK** to close the message.
2. If you have a Pocket PC 2002 model, do the following:
 - Open the **Start** menu and tap **Settings**.

- Tap the **Connections** tab.
- Tap the **Beam** icon.
- Clear the **Receive all incoming beams and select discoverable mode** check box.

SmartPad Batteries Run Down Quickly

Be sure you turn off the power to your handheld before you close the SmartPad portfolio. (To turn off the power, press and release the power button. If you hold the button down, it may perform another function. See your handheld documentation for more information.)

If you don't turn off the power, closing the portfolio might press buttons on the handheld. This keeps it active all the time—until the batteries run out!

See Also
“Power-Saving Features” on page 91

Service and Support

Seiko Instruments provides full support for their products. You can get technical help, replacement parts, and supplies.

This section explains how to:

- Contact Seiko Instruments
- Purchase supplies
- Obtain repair service

Contacting Seiko Instruments

If you have a problem that you cannot resolve, be sure you have reviewed the User's Guide. If you are still having problems using your InkLink or SmartPad, you can contact Seiko Instruments Inc. via telephone or World Wide Web:

- World Wide Web: www.seikosmart.com
- Telephone support:
 - United States: (800) 757-1011
 - Canada: (800) 757-1011

- United Kingdom: 00 800 727 97870
- France: 00 800 727 97870
- Germany: 00 800 727 97870
- Central Europe: 00 49 4105 1559 136
- Argentina: (54-1) 371-4123
- Brazil: (11) 241-9515

Purchasing Supplies

To purchase replacement supplies, visit your nearest Seiko Instruments reseller, or order directly from Seiko.

InkLink Supplies:

- Serial cable (IL-SER)
- USB cable (IL-USB)
- InkLink electronic pen (IL-PEN)
- InkLink pen cap (IL-CAP)
- InkLink pen stylus tip (IL-PDACAP)
- IrDA Transceiver (IL-IRDA)
- IrDA Transceiver clip (IL-CLIP)
- InkLink data clip (IL-BASE)
- InkLink carrying case (IL-CASE)
- InkLink refill pack of ink cartridges and batteries (IL-REFILL)

SmartPad Supplies:

- 5-inch x 8-inch writing pads (product code SP-NPAD580)
- Stylus cap for SmartPad pen (SP-CAP)
- SmartPad pen (SP-PEN)
- Ink refills for the SmartPad pen

-
- Black medium point (SP-BKM)
 - Black fine point (SP-BKF)
 - Blue medium point (SP-BLM)
 - Blue fine point (SP-BLF)

United States and Canada	www.seikosmart.com Phone: (800) 688-0817
United Kingdom	Phone: 0845 309 8028 Fax: 0845 309 8150
Germany	Phone: 0180 2000 217 Fax: 0180 2000 578
Europe	Phone: +49 6102 297 0

Repair Information for US and Canada

To return your Seiko Instruments product for repair, we do not require a Return Authorization Number (RMA) prior to shipping the product to our facility. However, you may wish to contact our technical support group at 1-800-757-1011 prior to sending your product, as they may be able to make suggestions that will eliminate the need for repair. If you should need to return the product for repair, then please return the product for repair to one of the following addresses. Be sure to include payment with the returned product. For your own protection, be certain you ship the product by UPS, Federal Express, or other traceable method. Products lost in transit to the Seiko Instruments repair facility are the responsibility of the customer. Freight costs to the Seiko Instruments Repair Center are the responsibility of the customer. Seiko Instruments will pay the shipping cost to return the product back to your location. Your repaired Seiko Instruments product will be repaired and sent back within two business days of receipt at the Seiko Instruments Repair Center.

Please include with your product the following information:

- Your return address
- Dated proof of purchase (to show the product is under warranty) for warranty repair or payment for out of warranty repair

Out of Warranty Repair Charges

InkLink and SmartPad (all models)

- USD \$80.00
- CAD \$123.00

Repair Center Addresses

Canada

GEAC Canada Ltd.
Attn: Seiko Repairs
11 Allstate Parkway, Suite 300
Markham, Ontario, Canada
L3R 9T8

United States

Seiko Instruments
Attn: BHD repair
2990 Lomita Blvd.
Torrance, CA 90505

Repair Information for other Regions

Please return the product for repair to one of the addresses below. Be sure to include payment with the returned product. For your own protection, be certain you ship the product by UPS, Federal Express or other traceable method. Products lost in transit to the repair facility are the responsibility of the customer. Freight costs to the Repair center are the responsibility of the customer. SII will bear the shipping cost of the return trip.

Please include with your printer the following information:

- Your return address.

-
-
- Dated proof of purchase (to show the product is under warranty) for warranty repair or payment for out of warranty repair.

For out-of-warranty repair costs, please contact your nearest repair center.

Repair Center Addresses

Argentina	Mega Tech S.A. Lavalle 1590 (1048) Buenos Aires, Argentina tel: (54-1) 371-4123
Brazil	ONLINE AV. dos Bandierantes, 1460 - Brook- lin CEP 04553-001 - Sao Paulo, Brazil tel: (11) 241-9515
Finland	Paricad OY Olarinluoma 16 FIN-02200 ESPOO Finland tel: +358-9-4523 577 fax: +358-9-4125 475
France	Papyrus Software-Entwicklung GmbH Hainbuchenweg 14-18 21224 Rosengarten b. Hamburg Germany tel: +49 4105 55 67 0 fax: +49 4105 55 67 50
Germany	Papyrus Software-Entwicklung GmbH Hainbuchenweg 14-18 21224 Rosengarten b. Hamburg Germany tel: +49 4105 55 67 0 fax: +49 4105 55 67 50

Netherlands

Compac b.v.
Franciscusweg 291
Hilversum
Netherlands
tel: +31 35-626 06 33
fax: +31 35-624 15 78

Sweden

Memstore AB
Truckvägen 16
Box 2027
S-194 02 Upplands Väsby
Sweden
tel: +46 8 5909 2000
fax: +46 8 5909 1733

Switzerland

Lab Plus AG
Kirchacherstr. 9
CH-8608 Bubikon
Switzerland
tel: +41-55 243 38 77
fax: +41-55 243 38 75

United Kingdom

Seiko U.K. Ltd.
Hattori House Vanwall Road
Maidenhead, Berkshire SL6 4UW
United Kingdom
tel: +44-1628-770988
fax: +44-1628-770655

SEIKO Precision U.K.
S.C. House Vanwall Road
Maidenhead, Berkshire SL6 4UW
United Kingdom
tel: +44-1628-587400
fax: +44-1628-587401

Warranty Information

Limited Warranty on Hardware

One (1) *Year Limited Warranty

Seiko Instruments USA Inc. warrants this product against defects in materials and workmanship for a period of one (1) *year from the date of original retail purchase (proof of purchase required). If Seiko Instruments USA Inc. receives notice of such defects during the warranty period, Seiko Instruments USA Inc. will either, at its option, repair or replace products which prove to be defective.

* Two (2) years as mandated by law in member countries of the European Parliament

Exclusions

The above warranty shall not apply to defects resulting from: improper or inadequate maintenance by customer; customer-supplied software or interfacing; unauthorized modifications or misuse; operation outside of the environmental specifications for the product; or improper site operation and maintenance.

Obtaining Warranty Service

To obtain warranty service, products must be returned to a service facility designated by Seiko Instruments USA Inc. Customer shall prepay shipping charges for products returned to Seiko Instruments USA Inc. for warranty service and Seiko Instruments USA Inc. shall pay for return of the products to customer. However, customer shall pay all shipping charges, duties and taxes for products returned to Seiko Instruments USA Inc. from another country.

Warranty Limitations

Seiko Instruments USA Inc. makes no other warranty, either expressed or implied, with respect to this product. Seiko Instruments USA Inc. specifically disclaims the implied warranties of merchantability and fitness for a particular purpose. Some states or provinces do not allow limitations on the duration of an implied warranty, so the above limitations or exclusion may not apply to you. However, an implied warranty of merchantability or fit-

ness is limited to the one year duration of this written warranty. This warranty gives you specific legal rights, and you may also have other rights which may vary from state to state, or province to province.

Exclusive Remedies

The remedies provided herein are customers sole and exclusive remedies. In no event shall Seiko Instruments USA Inc. be liable for any direct, indirect, special, incidental or consequential damages, whether based on contract, tort, or any other legal theory. Some states or provinces do not allow the exclusion or limitations of incidental or consequential damages, so the above limitation or exclusion may not apply to you.

Limited Warranty on Media

If you discover physical defects in the guide distributed with the InkLink or SmartPad, or on the media on which software is distributed, Seiko Instruments USA Inc. will replace the guide or media at no charge to you, provided that you return the items to be replaced during the 90-day period following your purchase of the InkLink or SmartPad.

All implied warranties on the media or guide, including implied warranties of merchantability and fitness for a particular purpose, are limited in duration to ninety (90) days from the date of the original retail purchase of the product.

Even though Seiko Instruments USA Inc. has tested the software and reviewed the documentation, Seiko Instruments USA Inc. makes no warranty or representation, either express or implied, with respect to software, its quality, performance, merchantability, or fitness for a particular purpose. As a result, the software is sold as is, and you the purchaser are assuming the entire risk as to its quality and performance. In no event will Seiko Instruments USA Inc. be liable for direct, indirect, special, incidental, or consequential damages resulting from any defect in the software or its documentation, even if advised of the possibility of such damages. In particular, Seiko Instruments USA Inc. shall have no liability for any programs or data stored in or used with the InkLink or SmartPad, including the costs of recovering such programs or data. The warranty and remedies set forth

above are exclusive and in lieu of all others, oral or written, express or implied.

Some states do not allow the exclusion or limitation of implied warranties or liability for incidental or consequential damages, so the above limitation or exclusion may not apply to you. This warranty gives you specific legal rights, and you may also have other rights which vary from state to state.

Copy Protection

The InkLink and SmartPad program disks are not copy-protected. You may make backup copies for your own use, but this doesn't mean you can make unlimited copies. The program is protected by the copyright laws that pertain to computer software. It is illegal to make copies of the disks without written permission from Seiko Instruments USA Inc. In particular, it is illegal to give a copy of the program or your spare set of disks to another person.

Other Information

FCC Compliance Statement

This equipment has been tested and found to comply with the limits for a Class B digital device, pursuant to Part 15 of the FCC rules. These limits are designed to provide reasonable protection against harmful interference in a residential application. This equipment generates, uses and can radiate radio frequency energy and, if not installed and used in accordance with the instructions, may cause harmful interference to radio communications. However, there is no guarantee that interference will not occur in a particular installation. If this equipment does cause harmful interference to radio or television reception, which can be determined by turning the equipment off and on, the user is encouraged to try to correct the interference by one or more of the following measures:

- Reorient or relocate the receiving antenna.

- Increase the separation between the equipment and receiver.
- Connect the equipment into an outlet on a circuit different from that to which the receiver is connected.
- Consult the dealer or an experienced radio/TV technician for help.

Changes or modifications not expressly approved by Seiko Instruments could void the user's authority to operate the equipment.

Index

A

action items 63

adding pages 50

archive 85

- options 86

- restoring 87

- saving 88

- viewing 87

archiving

- ink notes 85

attaching handheld 35, 104

B

backing up ink notes 85

batteries

- installing InkLink pen 26

- installing IrDA transceiver 25

- installing SmartPad portfolio 33

- replacing InkLink pen 98

- replacing IrDA transceiver 99

- replacing SmartPad pen 101
- replacing SmartPad portfolio 102
- battery compartment 16
- beaming ink notes 83
- business card holder 16
- C
- carrying case, InkLink 13, 31
- categories
 - assigning 59
 - setting up 62
- closing Note Editor 54
- colors, setting 75
- communicating ink notes 81
- configuration options 89
- creating ink notes 50
- D
- data clip 13
 - attaching 26
- default file name 90
- deleting ink notes 51
- E
- editing ink notes 65, 72, 77
- e-mailing ink notes 82
- Explorer 41
 - changing views 58
- exporting ink notes 52
- F
- file name, default 90
- finding ink notes 57
- function keys, pen 69
- G
- gestures, SmartPad pen 70, 113
- grouping elements 78
- H
- handheld

- as a partner 38
- attaching to SmartPad 35, 104
- connecting InkLink 28
- multiple devices 95
- testing 110
- handwriting recognition 79
- help 45
- highlights 74
- I
- infrared transceiver
 - repositioning 34, 103
- infrared transmitter 15
- ink cartridge 16
 - replacing InkLink 97
 - replacing SmartPad 100
- ink notes 48
 - adding to 72
 - archiving 85
 - backing up 85
 - beaming 83
 - changing pages 68
 - colors 75
 - communicating 81
 - creating 50
 - deleting 51
 - editing 65, 77
 - e-mailing 82
 - exporting 52
 - finding 57
 - grouping elements 78
 - highlights 74
 - linking to action items 63
 - moving part of 78
 - opening 66
 - organizing 55

- panning 67
 - printing 83
 - renaming 62
 - restoring archived 87
 - saving 51
 - selecting parts of 76
 - sending 81
 - storage location 96
 - undoing edits 79
 - ungrouping elements 78
 - viewing archived 87
 - zooming 67
- InkLink
- attaching data clip 26
 - carrying case 13, 31
 - connecting to desktop computer 28
 - connecting to handheld 28
 - data clip 13
 - IrDA transceiver 13
 - pen 13
 - pen function keys 69
 - testing 110
 - using pen 29
- InkLink pen
- replacing battery 98
 - replacing ink cartridge 97
- InkNote Manager
- starting on desktop computer 37
 - starting on Palm 37
 - starting on Pocket PC 36
 - uninstalling from desktop computer 106
 - uninstalling from Palm 107
 - uninstalling from Pocket PC 106
 - upgrading 107
- installing

InkLink pen batteries 26
IrDA transceiver battery 25
SmartPad pen ink cartridge 100
SmartPad portfolio batteries 33, 102
software 22

IrDA transceiver 13
 attaching to handheld 28
 installing battery 25
 replacing battery 99

K

keyboard, using tablet as 90

keywords 59

L

lines, straight 73, 74, 114

linking ink notes to action items 63

location of ink notes 96

M

maintenance
 InkLink 97
 InkNote Manager 106
 SmartPad 99

moving 78

multiple handheld devices 95

N

Note Editor 43
 closing 54, 70, 113
 ruled lines 71

notepad 16

O

opening ink notes 66

options
 archive 86
 configuration 89

organizing ink notes 55

P

pages

- adding 50
- navigating 68, 70, 113

Palm

- as a partner 38
- attaching to SmartPad 35, 104
- connecting InkLink 28
- multiple devices 95
- testing 110

panning 67

pen

- gestures 70, 113
- InkLink 13
- installing InkLink batteries 26
- proper use of InkLink 29
- replacing InkLink battery 98
- replacing InkLink ink cartridge 97
- replacing SmartPad battery 101
- replacing SmartPad ink cartridge 100
- SmartPad 16

pen function keys 69

Pocket PC

- as a partner 38
- attaching to SmartPad 35, 104
- connecting InkLink 28
- multiple devices 95
- testing 110

power saving 91

power, excessive use 116

printing ink notes 83

problems, troubleshooting 109

R

removing software 106, 107

renaming ink notes 62

repair information 119, 120

replacing

- InkLink pen battery 98
- InkLink pen ink cartridge 97
- IrDA transceiver battery 99
- SmartPad notepad 16
- SmartPad pen battery 101
- SmartPad pen ink cartridge 100

repositioning infrared transceiver 34, 103

restoring 87

ruled lines 71, 114

S

saving ink notes 51

saving power 91

selecting 76

sending ink notes 81

service 117

setup procedures 22

SmartPad

- as keyboard 90
- testing 110

SmartPad pen 16

- replacing battery 101
- replacing ink cartridge 100

software installation 22

straight lines 73, 74, 114

support 117

T

tablet

- as keyboard 90

tasks 63

technical support 117

testing InkLink 110

testing SmartPad 110

troubleshooting 109

U

undo 79

ungrouping elements 78

uninstalling software 106, 107

upgrading software 107

V

views, Explorer 58

W

warranty 122

Z

zooming 67